

EST-275 R 4C 1277 4
RICHARD B FONES JR
25 BALTIMORE-ANNAPOLIS
BLVD-FERNDALE
GLEN BURNE MD 21061

October, 1975 □ 75 cents

Electronic Servicing



A HOWARD W. SAMS PUBLICATION



Covering
NATESA and **NESDA**
conventions



All About Rectification

Eight-Track Workshop

Starting A CB Business



Let us solve your tuner problems

PTS will repair any tuner—no matter how old or new. Fastest Service—8 hour—in and out the same day. Overnight transit to one of our strategically located plants. Best Quality—you and your customers are satisfied.

PTS uses only ORIGINAL PARTS! No homemade or make-do, inferior merchandise (this is why we charge for major parts!). You get your tuner back in ORIGINAL EQUIPMENT condition.

PTS is recommended by more TV Manufacturers than any other tuner company and is overhauling more tuners than all other tuner services combined.

We're proud to announce the Grand Opening of our new Service Centers in Los Angeles, Columbus, Ohio, Phoenix, Boston, Norfolk & Indianapolis

Precision Tuner Service

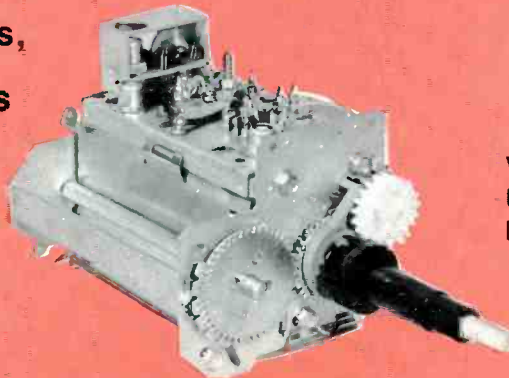

VHF, UHF \$10.95
 UV-COMBO 17.95
 IF-SUBCHASSIS .. 12.50

Major parts and shipping charged at cost. (Dealer net!)



ELECTRONICS, INC.

Home Office	Bloomington, Indiana	47401	5233 S. Highway 37	812-824-9331
Alabama	Birmingham, Alabama	35222	524 32nd St. So.	205-323-2657
Arizona	Phoenix, Arizona	85061	2412 W. Indian School Rd.	602-279-8718
California	Los Angeles, Ca. Central	90023	4184 Pacific Way	213-256-3728
	Sacramento, Ca. No.	95841	4611 Auburn Blvd.	916-482-6220
	San Diego, Ca. So.	92105	5111 University Ave.	714-230-7070
Colorado	Arvada, Colorado	80091	4958 Allison St.	303-423-7080
Florida	Jacksonville, Fla. No.	32210	1918 Blanding Blvd.	904-389-9952
	Miami, Fla. So.	33168	12934 N.W. 7th Ave.	305-635-9811
Indiana	Bloomington, Ind.	47401	5233 S. Highway 37	812-824-9331
Kansas	Kansas City, Kansas	66106	3116 Merriam Lane	913-831-1222
Louisiana	Metairie, La.	70003	2914 Wytchwood Dr.	504-835-2349
Maryland	Silver Springs, Md.	20910	1105 Spring St.	301-565-0025
Massachusetts	Somerville, Mass.	02144	52 Holland St.	617-666-4770
	Springfield, Mass.	01103	191 Chestnut St.	413-734-2737
Michigan	Detroit, Mich.	48235	13709 W. 8 Mile Rd.	313-862-1783
Minnesota	Minneapolis, Minn.	55408	815 W. Lake St.	612-824-2333
Missouri	St. Louis, Mo.	63130	8456 Page Blvd.	314-428-1299
New Jersey	E. Paterson, N. Jersey	07407	158 Market St.	201-791-8380
New York	Buffalo, New York	14212	993 Sycamore St.	716-891-4935
North Carolina	Charlotte, N. Car.	28205	724 Seigle Ave.	704-332-8007
Ohio	Cinn., Ohio	45215	8180 Vine St.	513-821-2298
	Columbus, Ohio	43227	4003 E. Livingston Ave.	614-237-3820
	Parma, Ohio	44134	5682 C'tate Rd.	216-845-4480
Oklahoma	Oklahoma City, Ok.	73106	3007 N. May	405-947-2013
Oregon	Portland, Oregon	97213	5220 NE Sandy Blvd.	503-282-9636
Pennsylvania	Pittsburgh, Pa.	15202	257 Riverview Ave. W.	412-761-7648
	Upper Darby, Pa.	19082	1742-44 State Rd.	215-352-6609
Tennessee	Memphis, Tenn.	38118	3614 Lamar Ave.	901-365-1918
Texas	Houston, Texas	77032	4324-26 Telephone Ave.	713-644-6793
	Longview, Texas	75601	Mopac Rd.	214-753-4334
Virginia	Norfolk, Va.	23504	3118 E. Princess Anne Rd.	804-625-2030
Washington	Seattle, Wash.	98108	432 Yale Ave.	206-623-2320
Wisconsin	Milwaukee, Wis.	53215	3509 W. National	414-643-8800

1

PTS

IS
NUMBER ONE
AND
STILL
TRYING
HARDER

●

WE OFFER
FINER
FASTER
8 hr.
SERVICE

●

1 YEAR
GUARANTEE

●

NOT A
FRANCHISE
COMPANY

For More Details Circle (1) on Reply Card

Convention Reports

By Carl Babcoke

NATESA

This year the national convention of the National Alliance Of Television & Electronic Service Associations (NATESA) was held August 7-10 in St. Charles, Illinois at the Pheasant Run, a vacationer's paradise. Business sessions, elections, seminars, and sponsored meals followed one another in a relaxed and friendly atmosphere.

Reports from industry leaders during the meals and meetings were by executives of NEDA, EIA, General Electric, GTE-Sylvania, RCA, Sony, and Zenith. S. I. Neiman, of the Electronic Industry Information Bureau, said service technicians are losing touch with the public, then when they're attacked on TV or by the press, they raise a spectacular publicity row that solves nothing. He urged NATESA members to "act instead of reacting", and suggested cooperative effort with the other service organizations in starting a national program to educate the public about technicians. Jack Sauter, Vice-President of the RCA Consumer Electronics division stated that the seven RCA Distributing branches would not pre-bill the new

\$19.95 dealer-cost nine-month service contracts offered by the RCA Service Company, that the sales division was not subsidizing any costs of the service contracts, and was not making available any warranty-registration cards to the RCA Service Company.

Frank J. Moch was renamed Executive Director, by a unanimous vote. Many conventioners remarked about the efficient way the agenda was handled, and the growing strength and optimism in the ranks of NATESA.

Recently, the Illinois Word (NATESA Chicagoland publication) carried details about the formation of the Centurians, a voluntary organization dedicated to helping NATESA expand its industry activities and to counteract the effect of inflation on the budget. At that time, more than \$4500 had been contributed by about 20 individuals and businesses. George Weiss says, if you want to participate in this unofficial program, make the check payable to NATESA SCOPE, and mail it to him at 4625 North Kedzie, Chicago, Illinois 60625.

NESDA

Winston-Salem, North Carolina was the location August 13-17 for simultaneous conventions of the Electronic Technicians Association of North Carolina (ETA), International Society of Certified Electronic Technicians (ISCET), and National Electronic Service Dealers Association (NESDA). Newly-elected NESDA officials are: Leroy Ragsdale, president; Everett Pershing, senior vice-president; John McPherson, secretary; and John Kelly, treasurer.

Some of the awards include: Man Of The Year Award Plaque to Larry Steckler; Jack Betz Memorial Award Plaque to Frank Killpatrick, Jr.; Hal Chase Memorial Award Plaque to Hershall Lawhorn; plaque for outstanding NESDA National Committee Chairman to Gerald Hall; plaque for Outstanding National NESDA Officer for 1975 to former president Charles R. Couch, Jr.; Outstanding State Association publi-

cation award to the Arizona "Scanner" edited by Paul Esch; and Outstanding Local Association Publication award to "CETA NEWS" edited by Ken Parese.

Individual awards for Special Recognition also went to Stan Prentiss, Miles Sterling, James Ballard, and J. A. "Sam" Wilson. Technician Of The Year Award was presented by ISCET to Atahusian E. Emadi, CET, of Camp Hill, Pennsylvania.

Dick Pavek of Tech Spray was the keynote speaker. Other major speakers included James A. Brodsky of USCPSC, Frank McLaughlin of the Office of Consumer Affairs, Jack Wayman of EIA, Jesse Bogan of the Council of BBB, and John Phelan of the FTC.

This year, the Trade Show featured a circus theme, complete with balloons, popcorn, prize drawings, barkers, and occasional seminars.

Editorial Remarks

Three national associations serve the home-entertainment industry. NARDA appears to find membership principally among retail sales dealers who have secondary service facilities. NATESA is for retail shop owners, especially those whose main business is service. Basically, NESDA also is an organization of shop owners and managers, but has a strong division for the technicians

in ISCET, which administers the CET tests.

All three organizations are worthy of your support. In fact, some shop owners belong to all three, evidently believing the benefits outweigh the extra costs. I hope these associations will cooperate even more in the future regarding the solution of pressing national problems.

Here are the association addresses:

NARDA
318 West Randolph Street
Chicago, Illinois 60606

NATESA
5908 South Troy Street
Chicago, Illinois 60629

NESDA (and ISCET)
1715 West Expo Lane
Indianapolis, Indiana 46224

Pictorial report of the conventions



Frank J. Moch, Executive Director, was in charge of the recent NATESA convention in St. Charles, Illinois.



NATESA officers for the 1975-1976 year are: (at left) Harold C. Larson, former treasurer, who administered the oath of office; Leon Skalish, former president; Philip E. Holt, Jr., president; Richard Ebare, treasurer; George Weiss, vice-president; Leo P. Shumavon, secretary-general; and Frank J. Moch, executive director.

William Watson gave a slide-illustrated description of the experimental Zenith laser video-disc system for NATESA delegates. Actual discs were played for demonstrations in the Zenith hospitality room. Quality of the newer discs was quite good.



Dick Pavak, of Tech Spray, was keynote speaker at the NESDA convention.



Dick Glass was one of the instructors at the NESDA Business Management School.



J. A. "Sam" Wilson provided facts and chuckles in his seminar on the general-type of questions most missed in the CET examination.



Clowns, balloons, and "kids" helped give a circus atmosphere to the NESDA Trade Show.



All three living members of the NESDA Hall Of Fame were present. Left to right are: M. L. Finneburgh, Sr., John P. Graham, and Vincent J. Lutz.



New officers of ISCET (left to right) are: Larry Steckler, chairman; Ron Palluth, vice-chairman; Frank Grabiec, secretary; and George Sopocko, treasurer.

Chassis—Magnavox T989
PHOTOFACT—1418-2

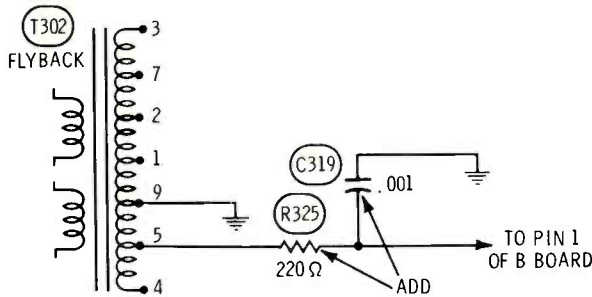

Symptom—Broad vertical bars at left edge of screen
Cure—Look for R325 and C319. Add them, if they are missing

Chassis—Magnavox T989
PHOTOFACT—1418-2

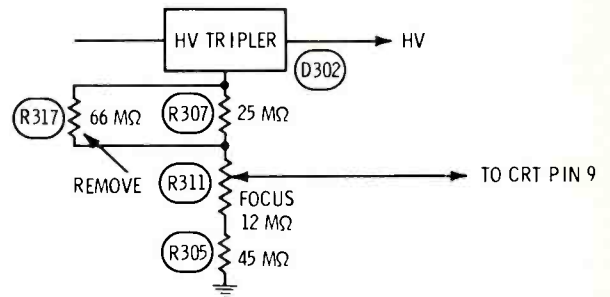

Symptom—Focus control at end for best focus
Cure—Remove R317, and check focus action

Chassis—Magnavox T989
PHOTOFACT—1418-2

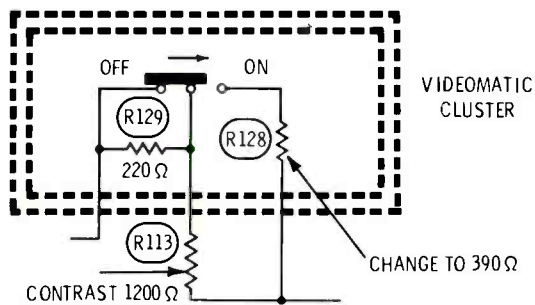

Symptom—Excessive when Videomatic is turned on
Cure—Check R128, if any other value change it to 390 ohms

Chassis—Magnavox T989
PHOTOFACT—1418-2

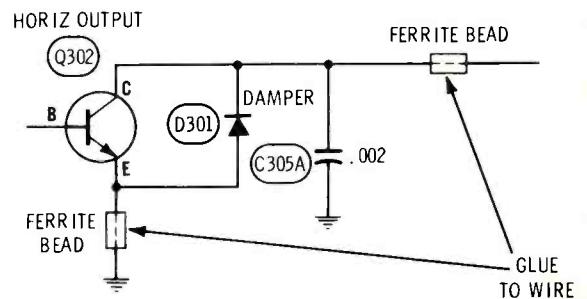

Symptom—Squeal from the horizontal-output circuit
Cure—Fasten the ferrite beads to wires by using epoxy

Chassis—Magnavox T989
PHOTOFACT—1418-2

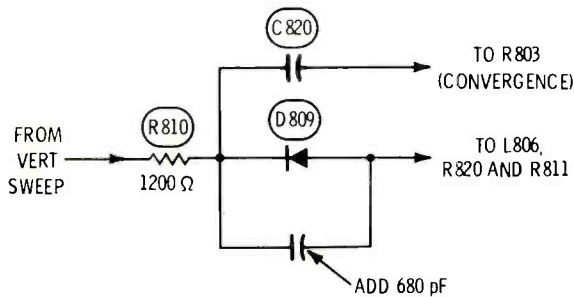

Symptom—A dark half-circle pattern near top of screen, especially on UHF reception
Cure—Parallel D809 (convergence board) with a 680 pF capacitor

Chassis—Magnavox T989
PHOTOFACT—1418-2

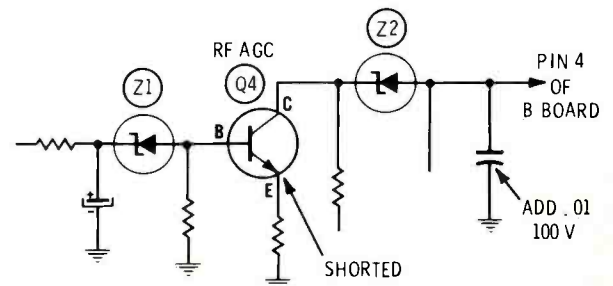

Symptom—Failure of Q4, RF AGC transistor
Cure—When replacing Q4, add a .01-100V capacitor, as shown, to prevent recurrence

electronicscanner

news of the industry

Formation of the NARDA Traffic Builder Division has been authorized by the National Appliance And Radio-Electronic Dealers Association. By combining the buying power of thousands of NARDA dealers, the association hopes to buy private-label merchandise at lower-than-usual prices.

False-advertising complaints about color TV servicing claims in ads **have been issued by the Federal Trade Commission** against General Electric and Panasonic. The FTC complained that GE did not have a reasonable basis for claiming less service for GE receivers. Also, the commission seeks to ban any misrepresentation of survey or test results from the advertising of both companies. Spokesmen for GE and Panasonic have stated their companies will oppose the complaints, according to **Home Furnishings Daily**. Complaints against RCA, Zenith, Philco-Ford and GTE-Sylvania might be filed in the future.

Sony recently demonstrated a new color TV projection system. The \$2,500 unit, Model KP-4000, has a 12-inch Trinitron picture tube, a specially-designed chassis, and remote control. To protect the 40-inch screen, the projection cradle folds, when not in use.

A new standard for loudspeakers has been released by the Electronic Industries Association (EIA) in publication RS-426. Tests to prove the maximum power rating of speakers use a test signal of "white" noise that has been filtered to approximate the power curve of average program material.

Production of CB radios is being sharply increased by most Japanese manufacturers; some plan to double production figures. However, others probably will make only moderate increases, because of possible changes of FCC frequency allocation, which might make present products obsolete.

Alfred di Sciplo, President and Chief Executive Officer of the Magnavox Consumer Electronics Company, has been awarded an Honorary Doctor of Laws Degree by Northeastern University of Boston, Massachusetts.

General Electric parts now can be ordered by calling GE and giving your Master Charge or Bank Americard number. Parts are sent immediately. Also, GE repair kits have been revised. If you have all four kits, you have the typical repair parts needed to repair any GE set made from 1961 to 1975.

A 1.5 billion-watt laser that transmits discs of green light to help measure the precise distance between the earth and moon has been developed by GTE Sylvania. Designed for the National Aeronautics and Space Administration (NASA), the laser is in operation at the University of Hawaii's Institute for Astronomy observatory, where it also is used to study fluctuations in the moon's orbit and drift of the Hawaiian Islands. The laser's beam is transmitted through a telescope from the observatory and aimed by computers at reflectors placed by astronauts on the moon. Several seconds later, beam signals are returned, and computers measure the distance by calculating the transit time of the signals.

(Continued on page 8)

TUNER SERVICE CORPORATION

SUBSTITUNER

INTRODUCING
AT JUST

\$44.95
U.S.A. ONLY

WITH CABLES



ONE YEAR
GUARANTEE

STILL ONLY

\$9.95
U.S.A. ONLY



MAJOR PARTS
AND SHIPPING
CHARGED AT COST

FEATURES

- A UHF Tuner with 70 channels which are detented and indicated just like VHF channels.
- A VHF Hi Gain Solid State Tuner.
- AC Powered
- 90 Day Warranty

Demonstrate the **SUBSTITUNER** to your customers and show improved reception with their TV sets.

You may place your order through any of the Centers listed below.

PROVIDES YOU WITH A COMPLETE SERVICE FOR ALL YOUR TELEVISION TUNER REQUIREMENTS.

REPAIR

VHF OR UHF ANY TYPE (U.S.A. ONLY) \$ 9.95
UHF/VHF COMBINATION (U.S.A. ONLY) \$15.00

MAJOR PARTS AND SHIPPING
CHARGED AT COST

- Fast, efficient service at our conveniently located Service Centers.
- All tuners are ultrasonically cleaned, repaired, realigned, and air tested.

REPLACE

UNIVERSAL REPLACEMENT TUNER \$12.95 (U.S.A. only)

- This price buys you a complete new tuner built specifically by Sarkes Tarzian Inc. for this purpose.
- All shafts have a maximum length of 10½" which can be cut to 1½".
- Specify heater type parallel and series 450 mA. or 600 mA.

CUSTOMIZE

- Customized tuners are available at a cost of only \$15.95. With trade-in \$13.95. (U.S.A. only)
- Send in your original tuner for comparison purposes to any of the Centers listed below.



WATCH US
GROW

HEADQUARTERS	BLOOMINGTON, INDIANA 47401	537 South Walnut Street	Tel. 812-334-0411
ARIZONA	TUCSON, ARIZONA 85713	1528 S. 6th Ave.	Tel. 602-791-9243
CALIFORNIA	NORTH HOLLYWOOD, CALIF. 91601	10654 Magnolia Boulevard	Tel. 213-789-2720
	BURLINGAME, CALIF. 94010	1324 Marsten Road	Tel. 415-347-5728
	MODESTO, CALIF. 95351	123 Phoenix Avenue	Tel. 209-521-8051
FLORIDA	TAMPA, FLORIDA 33606	1505 Cypress Street	Tel. 813-253-0324
	FT./LAUDERDALE, FLORIDA 33315	104 S.W. 23rd St., Ray 15	Tel. 305-524-0914
GEORGIA	ATLANTA, GA. 30310	646 Evans St. S.W.	Tel. 404-758-2232
ILLINOIS	CHAMPAIGN, ILLINOIS 61820	405 East University Street	Tel. 217-355-8400
	SKOKIE, ILLINOIS 60078	5110 West Brown Street	Tel. 312-875-0230
INDIANA	INDIANAPOLIS, INDIANA 46204	112 West St. Clair Street	Tel. 317-832-3493
IOWA	WEST DES MOINES, IOWA 50265	822 Tenth Street	Tel. 515-277-0155
KENTUCKY	LOUISVILLE, KENTUCKY 40205	2244 Taylorsville Road	Tel. 502-452-1191
LOUISIANA	MONROE, LOUISIANA 71104	3025 Highland Avenue	Tel. 318-221-3027
MARYLAND	BALTIMORE, MARYLAND 21215	5505 Reisterstown Rd., Box 2624	Tel. 301-358-1186
MASSACHUSETTS	SPRINGFIELD, MASS. 01108	405 Dickinson St.	Tel. 413-788-8206
MISSOURI	ST. LOUIS, MISSOURI 63132	10630 Page Avenue	Tel. 314-429-0633
NEVADA	LAS VEGAS, NEVADA 89102	1412 Western Avenue No. 1	Tel. 702-384-4235
NEW JERSEY	TRENTON, NEW JERSEY 08638	901 North Olden Avenue	Tel. 609-393-0999
	JERSEY CITY, NEW JERSEY 07307	547-49 Tonnele Ave., Hwy. 1 & 9	Tel. 201-792-3730
N. CAROLINA	GREENSBORO, N.C. 27405	2914 E. Market Street	Tel. 919-273-6276
OHIO	CINCINNATI, OHIO 45218	7450 Vine Street	Tel. 513-821-5080
	CLEVELAND, OHIO 44109	4525 Pearl Road	Tel. 216-741-2314
OREGON	PORTLAND, OREGON 97210	1732 N.W. 25th Avenue	Tel. 503-222-9059
PENNSYLVANIA	PITTSBURGH, PA. 15209	503 ½ Grant Avenue	Tel. 412-821-4004
TENNESSEE	GREENVILLE, TENNESSEE 37743	1215 Snapps Ferry Road	Tel. 615-639-8451
	MEMPHIS, TENNESSEE 38111	3158 Barron Avenue	Tel. 901-458-2355
TEXAS	DALLAS, TEXAS 75218	11540 Garland Road	Tel. 214-327-8413
VIRGINIA	NORFOLK, VIRGINIA 23513	3295 Santos Street	Tel. 804-855-2518
CANADA	ST. LAJRENT, QUEBEC H4N-2L7	305 Decarie Boulevard	Tel. 514-748-8803
	CALGARY, ALBERTA T2H-0L1	448 42nd Avenue S.E.	Tel. 403-243-0971
		P.O. Box 5823, Stn. "A"	

IF YOU WANT TO BRANCH OUT INTO THE TV TUNER REPAIR BUSINESS,
WRITE TO THE BLOOMINGTON HEADQUARTERS ABOUT A FRANCHISE.

For More Details Circle (3) on Reply Card

(Continued from page 6)

Microwave ovens should enjoy a 50% increase of sales during the coming holiday season, according to an article in **Home Furnishings Daily**. Retailers believe that higher-priced units with extra features will continue to sell best. In-store demonstrations appear to be one reason for the extra sales.

Panasonic plans to enter the CB radio field with a monitor in October, and also with mobile and base station transceivers by next spring. Other manufacturers, such as Sony and Hitachi, expect to offer CB products very soon.

At the NARDA School Of Management recently held in Notre Dame University, one subject of discussion was the possible diversification of appliance-TV stores into selling other products. Some of the fields mentioned were furniture, financing, unpainted furniture, carpeting, photographic products, and sporting goods. Suggestions and warnings came from dealers who had expanded into other lines. For example, a separate sales staff should be provided for each basic category.

In Japan the Sony Corporation has demonstrated its 1/2-inch video-cassette recorder and playback unit for home use. The Betamax Videodeck is priced at \$766.00 for the Japanese domestic market. A 60-minute video-cassette tape is \$15.00, and a 30-minute tape is \$10.00. The unit has a two-head, helical-scanning mechanism. The high-density color recording system allows slow tape speed (1.57 inches-per-second) and uses about 494 feet of tape in a 60-minute cassette. Akira Morita, president of Sony, said dealer and market reaction will be surveyed before beginning sales in the United States, reports **Home Furnishings Daily**.

A joint effort by Tokyo Shibaura Electric and Toshiba Ray-O-Vac has developed a nickel-zinc 1.55 volt dry-cell battery, rechargeable up to 300 times. According to **Home Furnishings Daily**, the battery is believed to be the first nickel-zinc dry-cell battery that is rechargeable. The operating voltage of the battery is higher than nicad batteries (1.2 volts), and materials reportedly cost about 50 percent of those in nicad batteries.

RCA has introduced its new "Color Trak" line of deluxe color TV receivers. In the 19" and 25" Accufilter picture tubes, individual color filters are added to all red and blue color dots. This feature, plus the black-matrix type of phosphors, is said to provide better contrast and blacker blacks during adverse room lighting conditions. Other features include automatic tracking of color and contrast; automatic adjustment of skin colors; a ferroresonant power transformer for line voltage regulation; a circuit for adjusting the contrast, color, and brightness according to the intensity of room lighting; and a new solid-state chassis with six modules. The remote control circuitry has 10 special IC's containing the equivalent of about 5,000 transistors. TV-channel numbers and the time of day can be displayed on the screen, and the characters have a black outline so they have good visibility regardless of the picture over which they are superimposed. □

reader's exchange

Need a not-available schematic? Need an obsolete part? Have an unusual service problem and want help? Send information and full mailing address to ELECTRONIC SERVICING. Other ES readers should send replies with their offer of help direct to the writer. We reserve the right to edit and print all letters sent to this column. **Let us help one another.**

Needed: Schematic and operating instructions for Approved Electronic Instrument signal generator, Model A-200, and United Transformer P1A amplifier (with tube complement layout). Also need TVR power cable and operating instructions for Aerotron VHF FM transceiver, Model 600 series.

Fred Schmidt
36 Sweetbriar Road
R.D. 2
Butler, New Jersey 07405

For Sale: Antique Philco deluxe console radio Model 15 (1932) in good condition.

Albert C. Hart
207 North Raymond Avenue
Griffith, Indiana 46319

Needed: Operating manual, calibration data, or schematic for Hickok oscilloscope Model 670.

Durward Dostie
54 Academy Street
Amsterdam, New York 12010

Needed: Service notes and schematic for a Progress Sound-Guard home intercom system, Model 1050-68. Will buy original or copy.

Gus' Radio & TV Service
524 Station Avenue
Haddon Heights, New Jersey 08035

Needed: Main frame of Quasar LTS-938 or LJ19TS-931 to build test jig. Need not be operational; do not need picture tube, yoke, or cabinet. State price and condition.

Wolven TV
7477 Glasco Turnpike
Saugerties, New York 12477

Needed: Tube tester adapter panel, Model TC-615, with operating instructions for Dyna-Quik tube tester, Model 650.

David Munoz
2448 Rancho Drive
Riverside, California 92507

Wanted: Supreme TV Manuals, Volumes 26 to 29 and C-69 and 70. Also need color bar generator.

Irv Hornstien
428 West Roosevelt Boulevard
Philadelphia, Pennsylvania 19120

(Continued on page 12)

Brand new edition of an RCA best seller.

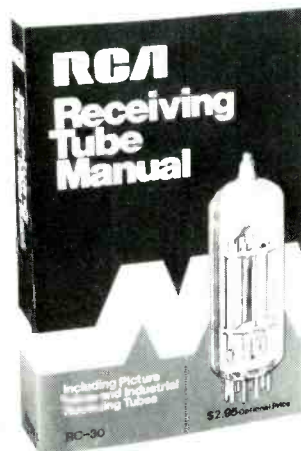

One of the most widely-used manuals in the electronics industry, the RCA Receiving Tube Manual, is now available in a new, updated edition, especially designed for use by technicians, engineers, educators, students and electronic hobbyists.

With 754 pages of tube information, the new manual — RC-30 — includes chapters on basic principles of operation, electrical characteristics, and circuit applications. It also features terminal diagrams, picture tube characteristics chart, and an updated receiving tube replacement guide.

Ask your RCA distributor for a copy of the new RC-30 at only \$2.95 (suggested price). Or send your check or money order for \$2.95 (plus 50¢ for postage and handling per order) to: RCA Distributor and Special Products Division, P.O. Box 85, Runnemede, N.J. 08078.

RCA Distributor and Special Products Division

For More Details Circle (17) on Reply Card

October, 1975

The Money Generator



A BETTER APPROACH TO TV ANALYZING

The ATC-10 is different from other color bar pattern generators. It's like a portable test lab with the versatility to perform the most commonly used functions of an analyst and a substitute tuner. It's a time saver for both in-home and on-the-bench servicing. That's why we've nicknamed it the MONEY GENERATOR. Since it takes more than a few words to describe the ATC-10's many unique features, we'd like to send you our big 4 page illustrated brochure.

This brochure tells you about the ATC-10's unique patterns which include RED RASTER, 3.58 MONITOR, GRAY QUAD, and HATCHDOTS. It also describes some unusual test capabilities such as: •A full range of crystal controlled RF, IF, and video injection signals •Receiver sensitivity and dynamic range checks using the calibrated RF output control •Fast accurate purity and 3.58 oscillator checks with no need to disable guns or short test point(s) •Extra clear oscilloscope and vector patterns •In-Home receiver bandpass checks at 60 Hz, 1.78 MHz, and 3.56 MHz •Complete convergence series using a single composite pattern (all of these and many more for only \$299.95.)

The brochure is free, but, if you'd like still more information on the operation of the ATC-10, you can obtain a copy of the 2 volume (home-shop) owner's manual. Just include \$1.00 for postage and handling. Act now and evaluate for yourself the many ways the ATC-10 can be a real MONEY GENERATOR for you.

Mail Request To:
AMERICAN TECHNOLOGY CORP.
Dept. 10A, Canon City, CO 81212

Name _____
Address _____
City _____
State _____ Zip _____

For More Details Circle (4) on Reply Card

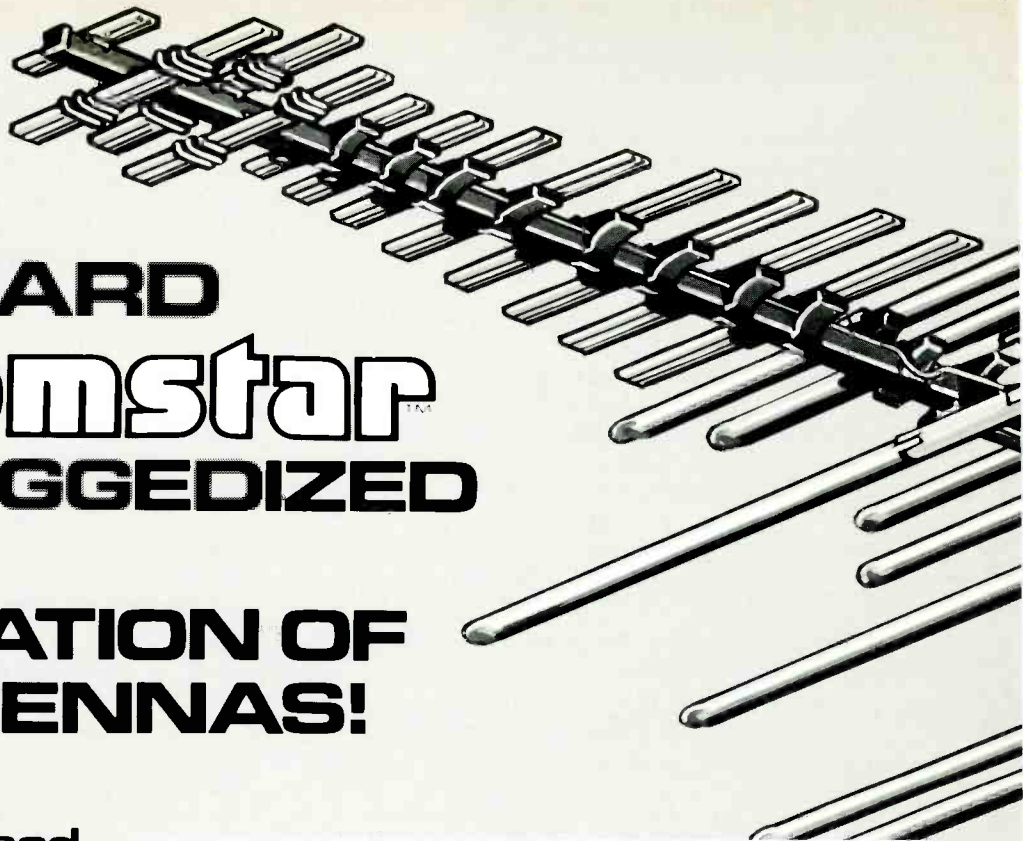

WINEGARD Chromstar™ THE RUGGEDIZED NEW GENERATION OF TV ANTENNAS!

**40 Models
With Far-Ahead
Features For
Finest Color
Reception Ever!**

**Ask your distributor
for complete information!**

- New Standard Of Excellence In Construction And Performance.
- Anodized and Ruggedized for Weather Protection and Long Life.
- Models To Solve Every Area Reception Problem.
- Most Powerful UHF and VHF Performance Ever.
- New Tri-Linear UHF Director System Extends UHF Reception Distance Up To 30 Miles Farther From Station in Many Areas.

PLUS... New Generation FM Antennas.
High Performance Ruggedized Yagis.
New Solid State Preampifiers.



WINEGARD
TELEVISION SYSTEMS

3000 KIRKWOOD
BURLINGTON, IOWA 52601

NEW TRI-LINEAR UHF DIRECTOR SYSTEM*

Increases Gain up to 30%!

Provides broader signal capture area in a more compact configuration.

ORDINARY UHF Director System.



5½"

Uses half-wave directors approximately 5½" long which respond primarily to the high end of the band, with very little gain on the low end.

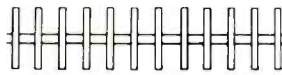

55"

Boom length required for 12 directors

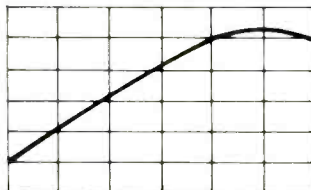

Typical gain curve with ordinary UHF directors.
Note low response on low end of band.

WINEGARD High Gain Tri-Linear® Directors

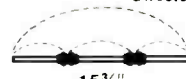

15¾"

Act as 3 half-wave directors on the high end of the band, and re-resonate as a loaded half-wave director on the low end of the band. This results in high linear gain on all UHF channels, giving the antenna sharper directivity and up to 30% more gain over other high gain UHF antennas.

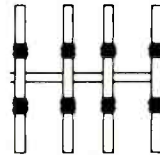

10"

Boom length required for 12 directors

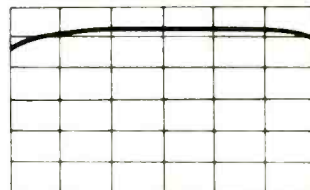

Typical gain curve with Winegard Tri-Linear directors. Note high uniform gain across entire band.

ANODIZED!

Exclusively Winegard! Elements are silver anodized, the boom blue anodized for the best possible protection for aluminum against corrosion and weather.

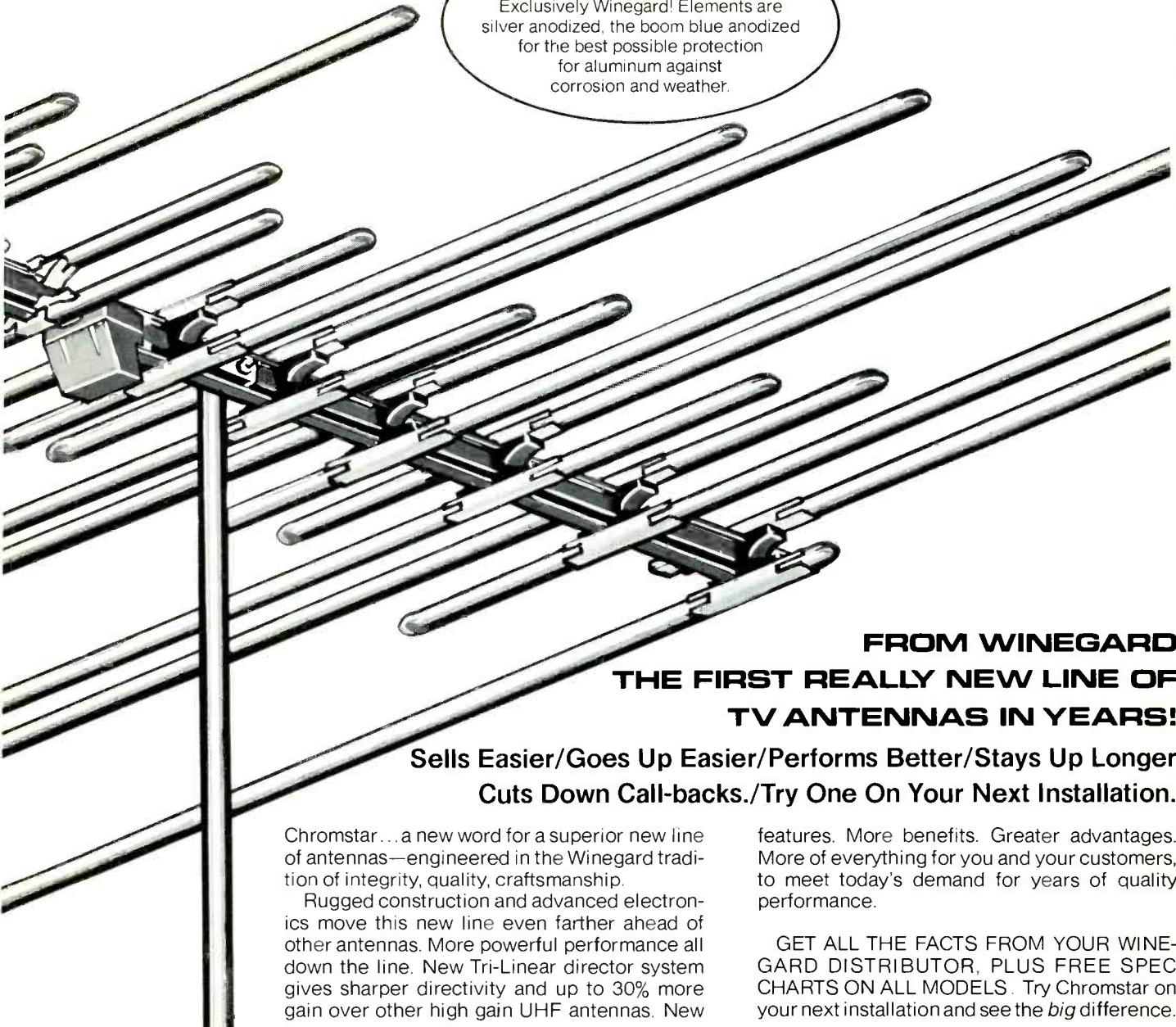

FROM WINEGARD THE FIRST REALLY NEW LINE OF TV ANTENNAS IN YEARS!

**Sells Easier/Goes Up Easier/Performs Better/Stays Up Longer
Cuts Down Call-backs./Try One On Your Next Installation.**

Chromstar... a new word for a superior new line of antennas—engineered in the Winegard tradition of integrity, quality, craftsmanship.

Rugged construction and advanced electronics move this new line even farther ahead of other antennas. More powerful performance all down the line. New Tri-Linear director system gives sharper directivity and up to 30% more gain over other high gain UHF antennas. New

features. More benefits. Greater advantages. More of everything for you and your customers, to meet today's demand for years of quality performance.

GET ALL THE FACTS FROM YOUR WINEGARD DISTRIBUTOR, PLUS FREE SPEC CHARTS ON ALL MODELS. Try Chromstar on your next installation and see the *big* difference.

RUGGEDIZED! Chromstar antennas are designed to defy weather and wear—are engineered for extra strength at all points of stress. You can actually see the difference in the rugged construction.



Exclusive 7/16" diameter aluminum tubing for 30% greater strength, better performance, longer life. Winegard is the first and only manufacturer to use this larger diameter.

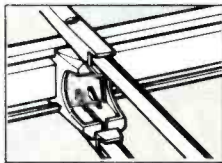

New truss-type phasing bars, top and bottom, with more conductive surface, give maximum transfer of signal. Truss-type "bridge" construction more than doubles boom strength.

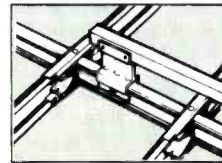

Double boom on longer flat line models for extra strength & rigidity.

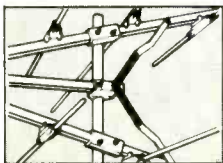

New scissors-type struts between upper and lower booms and center boom on wedge models, for extra support, easier installation.

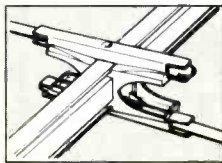

High-impact girder design support insulators are moulded of super-tough Noryl G-E plastic. Four positive locks give maximum support and permanent alignment.

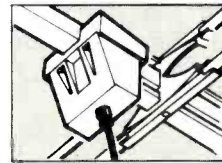

Critical-point weather protection! *New compact weatherproof cartridge housing for downlead, preamplifiers and filter modules. New printed circuit downlead module with both twin lead and 75 ohm coax connections. No separate matching transformer required.

TV ANTENNAS MORE PEOPLE LOOK UP TO

For More Details Circle (5) on Reply Card

Let me show you the pricing system that makes it easier for shop owners to make a profit.



tv & radio tech's guide to pricing



This system is proving itself in thousands of shops from coast to coast and Canada. It allows you to price your work profitably

with conviction... A new dimension in pricing...

keeps a true and proper balance between cost and work performed with computer like accuracy.

The original 6"x9" page size, hard cover, steel ring-bound issue for shop use remains available. It's the same system used in the Satellite described below. \$18.95 postage paid.

John C. Sperry

John C. Sperry

Now, the system goes pocket-sized

The advantages of using the pocket-sized pricing guide is obvious (even fits a shirt pocket) fast-tab indexing to 19 major repair categories... your own print out and guide to reliable pricing. It's all you'll ever need for fast errorless pricing in the field, bench, or over the counter... you can bank on it... \$16.95 postage paid, instruction manual included.



And, parts pricing right out of the same pocket!

Hundreds of man hours are lost every year hunting down various parts prices during billing time that can be drastically recovered by the parts Satellite. Over 3500 fast moving parts are cataloged and up-dated periodically. In ordering a parts Satellite, all you do is fill out and send in the coupon below. We then send you a three-page work sheet on which you show us the mark-up you desire for different parts categories... a computer printout is then made with your retail parts prices tabulated. It is then reduced and bound into a compact parts catalog. The initial programming and set up charge is \$75.00 plus \$10.00 for each catalog.

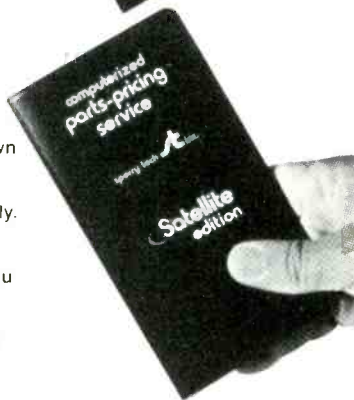

sperry tech inc. P.O. Box 5234 Lincoln, Nebraska 68505

- My check or money order enclosed for _____ copies of large (6"x9") pricing manual.
- My check or money order enclosed for _____ copies of the Labor Satellite.
- My check or money order enclosed for _____ copies of the Parts Pricing service.
- More information on all three.

Name _____

Company _____

Address _____

City _____ State _____ Zip _____

Ne. residents add City and State taxes U.S. Currency equivalent.

(Continued from page 9)

Needed: Used test equipment.
Paulmer Williams
106 South Jefferson Street
Lewisburg, West Virginia
24901

For Sale or Trade: Cartrivision video tape recorder. Make offer, or write for more information.

Art Steidl
10916 Arroyo Drive
Whittier, California 90604

Needed: Schematic for Philco radio Model 42-PT-7. Will buy.

Walter S. Opalach
982 Planetree Place
Sunnyvale, California 94086

Needed: Information about a method of removing the protective encapsulation on military circuit boards without destruction from chipping or heat.

Steven E. Collier
5610 Maxwell
Houston, Texas 77023

Needed: Operating manual for Du-Mont scope Model 304H. Will buy, or copy and return.

Troch's Television
290 Main Street
Spotswood, New Jersey 08884

Needed: Meter for Accurate Instrument tube checker Model 257, or details on type of meter.

Troch's Television
290 Main Street
Spotswood, New Jersey 08884

Needed: Zero-adjust control for a Precision VTVM Model EV-10.

T. L. Willis Radio & TV Service
P.O. Box 425
Salina, Kansas 67401

Needed: Operating information, schematic, and new tube chart for Model 805 tube/set tester by Radio City Products Company. Will buy, or copy and return.

Adrien Guay
375 Woodman Street
Fall River, Massachusetts 02724

**Ideas for articles?
Send them to ES, now!**

HV rectifier failures

Philco 20QT90 color chassis (Photofact 1126-2)

During the first service call to correct a complaint of "sound okay, but no raster", I replaced the usual horizontal-sweep tubes, including the 3AW2 high-voltage rectifier.

In about two weeks, the customer called back telling of the same symptoms. The 3AW2 was dead again. Now I knew it was time for a more-detailed analysis.

The high voltage was running between 27KV and 29KV, depending on brightness, and adjustment of

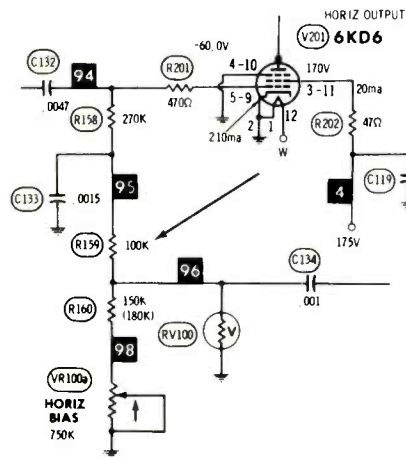

the HORIZ BIAS didn't change the voltage at all. After I removed the chassis and tuner from the cabinet, I measured the DC voltage at the grid of the 6KD6 horizontal output tube. Again there was no change when the HORIZ BIAS was adjusted.

According to the Photofact schematic, negative voltage from "rectification" by varistor RV100 of positive-going horizontal pulses is supposed to increase the -60 volt bias when the HV increases. Although the varistor is a prime suspect in such cases, I didn't have one on hand, so I proceeded with ohmmeter tests of all the resistors in the 6KD6 grid circuit.

R159 (100K) was found to be open. Replacement of the resistor and an adjustment of VR100a, HORIZ BIAS control, reduced the HV and restored the HV regulation.

The moral is to look for a cause, when any tube fails repeatedly.

Charles E. Jackson
Buckner, Illinois

Raster but no picture RCA b-w KCS169B chassis (Photofact 984-2)

Although a raster was on the screen, this b-w portable TV had no picture and no sound. The symptoms indicated a failure in the VHF tuner, a KRK146. But a measurement of AGC voltage at the white-with-blue-tracer wire at the tuner showed +10 volts DC. That is excessive forward (saturation-type) bias for the RF transistor, which usually operates at from 1.7 to 1.9 volts, and was killing all the RF gain.

To prove it was AGC trouble, I connected a resistor-substitution box in series with the RF AGC lead, and increased the resistance until the voltage dropped to about +1.5. Now sound was restored, and some faint video appeared on the screen.

I removed Q8, the AGC-amplifier transistor, and measured a low resistance between the B/C and B/E junctions, using both polarities of the ohmmeter. Q8 was very leaky, almost a dead short. Of course, the IF gain had been affected also, because Q8 feeds Q9, which controls the IF gain.

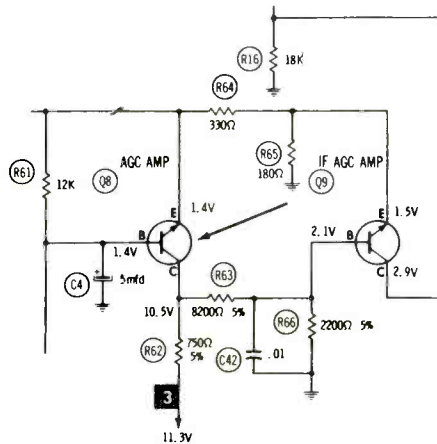

The RCA stock number for Q8 is 125143, but an RCA SK3122 or a GE-20 will substitute satisfactorily.

By measuring the AGC voltage, and finding it wrong, I was able to avoid a needless replacement or repair of the tuner.

Bernard H. Serota
Philadelphia, Pennsylvania

More chances to be right

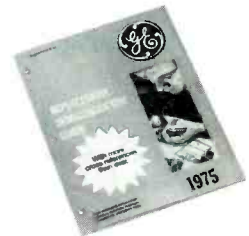

Thousands more cross references



Transistor kit for foreign sets



Replacement amplifier modules



All the help you need at your authorized distributor

Tube Products Department
General Electric Company
Owensboro, Kentucky 42301

GENERAL ELECTRIC

Everything we make has you in mind.

When you're looking for profitable electronic lines, look to RCA Distributor and Special Products Division:

TEST EQUIPMENT & ACCESSORIES

EXACT REPLACEMENT PARTS

SK REPLACEMENT SEMICONDUCTORS

FLAMEPROOF RESISTORS

COLOR & BLACK-AND-WHITE PICTURE TUBES

RECEIVING TUBES

INDOOR & OUTDOOR ANTENNAS

ANTENNA HARDWARE

ANTENNA ROTATORS

CAR RADIOS & TAPE PLAYERS

STEREO SPEAKER SYSTEMS

SCANNERS

BATTERIES

... AND MORE

See your RCA distributor. Or, for more information, contact RCA Distributor and Special Products Division, Bldg. 206-2 Cherry Hill Offices, Camden, New Jersey 08101.

RCA

Distributor and Special Products Division

Excessive high voltage Silvertone 529.72940 chassis (Photofact 1081-2)

After servicing this Sears color receiver for another trouble, we started the convergence and purity procedure, and measured an excessive 32KV of high voltage! We turned off the set and allowed it to cool. Next time, the HV built up to 22KV, held there for a couple of minutes, then started a slow climb to 30KV.

We looked at the Photofact schematic and found it was the kind that increased the negative grid bias of the horizontal-output tube to decrease the HV when the load was light. The varistor (or VDR) R148 seemed to have a crack across it. However, the symptoms were the same after it was replaced.

(C104) between the flyback pulses and the varistor became a suspect. After C104 was replaced, the high voltage could be adjusted to the required 25KV, and it would remain there for hours. Evidently C104 became leaky when it was warmed from the chassis heat.

Caution: always replace these pulse-coupling capacitors with new ones of equal or higher voltage ratings. Also notice that most have a temperature coefficient of around N1500, and the replacement should have the same rating as the original.

Joseph Rotello, Jr.
Tucson, Arizona

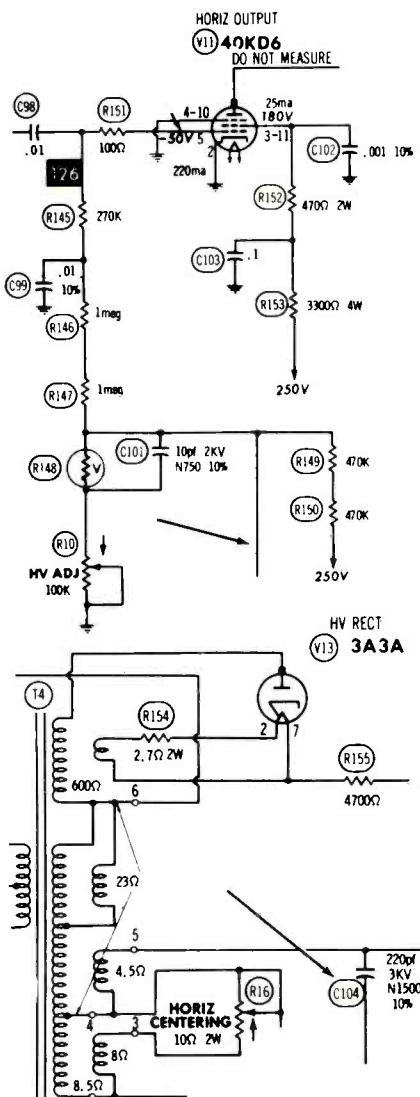

Ohmmeter tests showed none of the 40KD6 grid resistors to be out of tolerance. By the process of elimination, the coupling capacitor

You'll never know how much good you can do until you do it.

You can help people.

In fact, there's a crying need for you. Your talents. Your training. Your concerns. They make you valuable to your business. They can make you priceless to your community.

If you can spare even a few hours a week, call the Voluntary Action Center in your town.

Tear 'n Share

Save your RCA entertainment receiving tube carton ends* and color picture tube warranty serial number stickers* . . . and redeem them for discount certificates or valuable premiums. Just tear and you'll share!

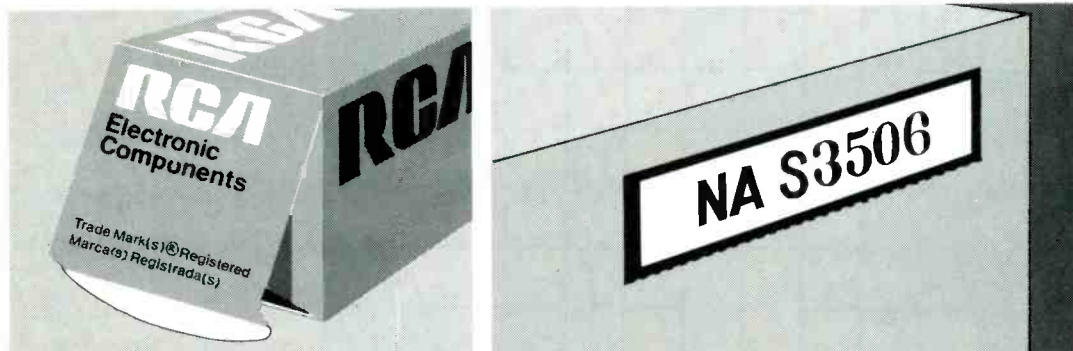

*Save the receiving tube carton end that is solid red reading RCA Electronic Components and the warranty serial number sticker that appears above the warranty envelope on the upper right hand corner of the RCA color picture tube carton. *One* color picture tube warranty serial number sticker is equal in value to 20 receiving tube carton ends.

Your RCA receiving tube carton ends are valuable! So are your RCA color picture tube warranty serial number stickers. Save them. In various quantities, they will bring you:

- Discount certificates. You can apply these toward purchases of more RCA receiving tubes and color picture tubes from your RCA Distributor.
- Popular merchandise premiums. You can choose from a wide selection for yourself, your family, or your home.

Here's how you do it. See your participating RCA Distributor. Pick up your copy of the RCA "Tear 'n Share" Prize Book and saver envelope. Mail the required number of RCA receiving tube carton ends or RCA color picture tube warranty serial number stickers in the envelope provided, specifying discount certificates or the premium you've selected to:

RCA Tear 'n Share Headquarters,
P.O. Box 154, Dayton, Ohio 45401.



RCA

Distributor and Special Products Division, Cherry Hill Offices, Camden, N.J. 08101

Time to go Ohm

Relax and have fun solving this Just-Across-Word Puzzle based on electronics. Each word is connected to the word above and below by at least one or more letters but only one is usually shown as a clue. Each correct answer is worth 4 points; a perfect score is 100. It should prove fairly easy to get a high rating except perhaps for someone who thinks "braze" is the speech of a donkey, or that "lightning arrester" is a speedy policeman! Sharpen your pencil, kick off your shoes (if you wanta), and GO!

by Edmund A. Braun

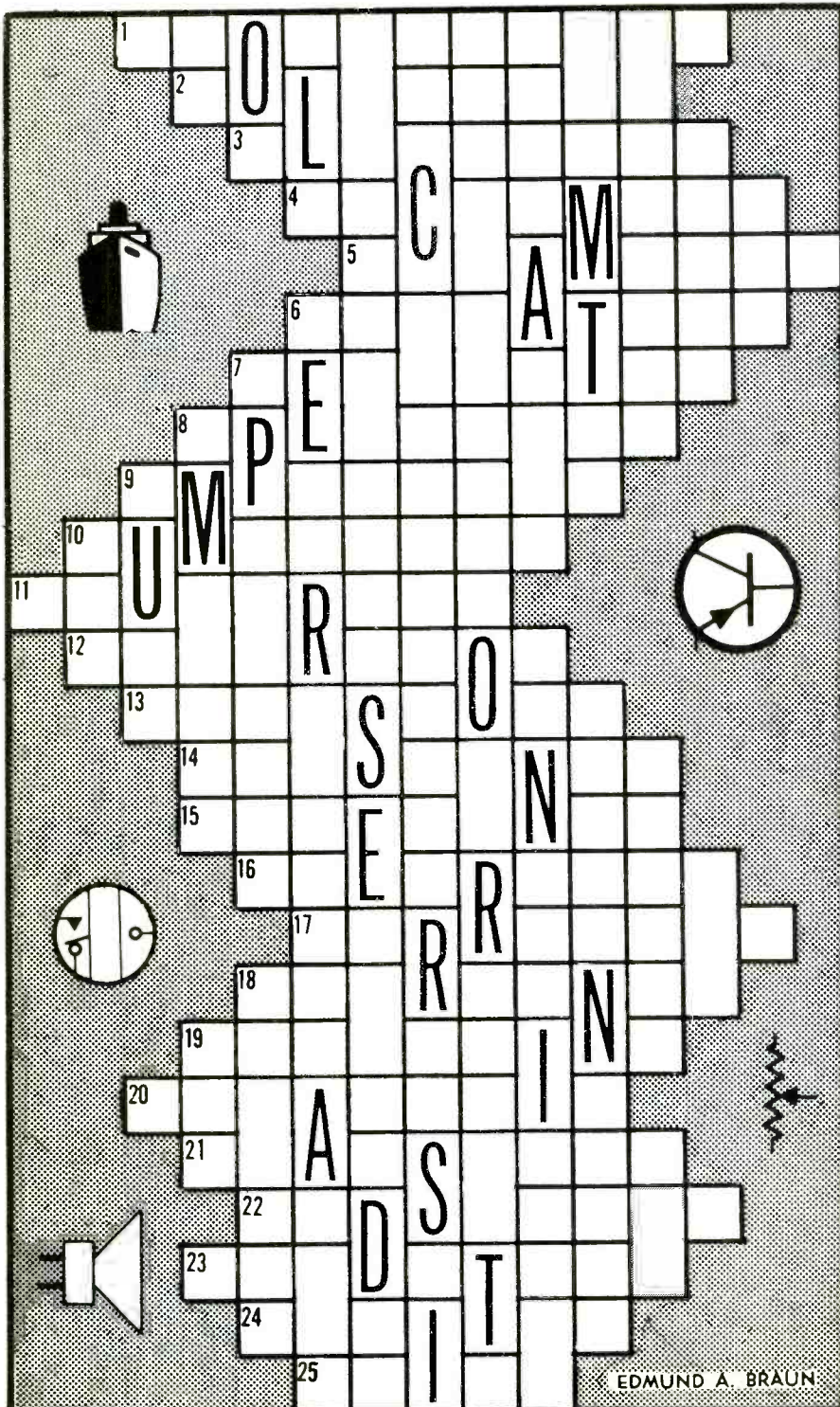

1. Lower level of earth's atmosphere.
2. A radiation detection device.
3. In the direction the hands of a timepiece rotate.
4. The decrease in value of a variable quantity.
5. Intentionally renders speech unintelligible by inverting frequencies.
6. Technique of rendering sound waves visible by using their ability to refract light waves.
7. A two-winding ferroresonant magnetic amplifier that operates on a high carrier frequency.
8. Radio circuit damped sufficiently to prevent oscillation.
9. The magnitude of a simple wave or part of a complex wave.
10. An emission of light radiation.
11. Heavy hydrogen.
12. Phosphorescence.
13. To convert current from one type to another, or from one magnitude to another.
14. Unvarying or fixed values.
15. Total opposition a circuit offers to the flow of AC.
16. Shortest distance between two live parts.
17. Voltage-regulator tube consisting of an iron-wire filament in a hydrogen-filled envelope.
18. Acoustical equivalent of inductance.
19. Metal covering used on a cable; a metal can surrounding an envelope.
20. Pertaining to a bowl-shaped reflector.
21. To interchange positions of conductors, especially in open wire circuits.
22. Type of broadside antenna array with a flat reflector.
23. Commonly known as rust when a ferrous metal is involved.
24. Device which automatically prevents output from exceeding a predetermined value.
25. Wavy or satiny effect on TV picture tube from converging lines nearly parallel with the horizontal scanning lines.

Already finished? You'll find the solution on page 54.

EDMUND A. BRAUN



This Craig Model 4102 is typical of the medium-priced CB transceivers. List price is \$149.95. (Courtesy of Craig Corporation)

STARTING A CB BUSINESS

By Marvin J. Beasley, CET

Sales of Citizen's Band radios have skyrocketed above all previous estimates; it is the success story of the decade. Declining TV repairs might make this a good time for you to begin repairing CB radios. Both the pros and the cons are discussed fairly, so you can decide about getting into the CB business.

When I suggest to electronics men that perhaps they should get into the business of servicing CB radio transceivers, one common reaction is: "Why should any technician want to have anything to do with those crazy radio nuts?" There are two strong answers to that question.

The profile of the average CB user is changing. For some years, many CBers appeared to be frustrated radio amateurs, who wanted the thrills of talking over the air, but didn't want to spend the time and effort to obtain a ham license. They used CB as a hobby, gossiping about equipment and long-distance contacts, or trying to outwit the law by reporting on "Smoky the bear, with his camera". It's true that CB customers of this type can waste an unreasonable amount of time in conversation.

However, many of the department and discount stores now are beginning to sell CB equipment, and their ads stress traffic and weather reports, rather than the hobby appeal. Therefore, more CB equipment is being used for business and family communications and not by the rabid "weirdos". Don't begin wrong, by allowing your shop or office to become a meeting area for CBers with endless questions and idle conversations,

and wasted time should not be a problem.

Secondly, **you can make a good profit from CB repairs.** Many service shops charge commercial two-way service rates, such as \$15 to \$22 per hour, with a one-hour minimum. Although you can make extra money from Remove-and-Reinstall (R&R) labor, many CB owners bring the transceivers to the shop and pick them up there. A majority of the repairs can be cash-and-carry. And most shops do in-warranty work for the manufacturers, to increase income and to become known among the CB owners.

Shop Requirements

The first requirement before you can repair anything in the transmitting section of a CB transceiver is an FCC license. Either a Second-Class Radiotelephone or a First-Class Radiotelephone license must be held by at least one technician in your organization. Other techs can work under his supervision.

If you have a subconscious fear of taking the FCC test perhaps you'll make all kinds of excuses why you shouldn't attempt it. Do you think the exam is too tough? Not so! You successfully studied to become a good TV technician. Many of you have passed the CET

Table 1. FCC FIELD OFFICES

Street addresses can be found
in local directories under
"United States Government."

Alabama, Mobile 36602
Alaska, Anchorage 99501
California, Los Angeles 90012
California, San Diego 92101
California, San Francisco 94111
California, San Pedro 90731
Colorado, Denver 80202
District of Columbia, Washington 20554
Florida, Miami 33130
Florida, Tampa 33602
Georgia, Atlanta 30303
Georgia, Savannah 31402
Hawaii, Honolulu 96808
Illinois, Chicago 60604
Louisiana, New Orleans 70130
Maryland, Baltimore 21201
Massachusetts, Boston 02109
Michigan, Detroit 48226
Minnesota, St. Paul 55101
Missouri, Kansas City 64106
New York, Buffalo 14023
New York, New York 10014
Oregon, Portland 97204
Pennsylvania, Gettysburg 17325
Pennsylvania, Philadelphia 19106
Puerto Rico, San Juan 00903
Texas, Dallas 75202
Texas, Houston 77002
Texas, Beaumont 77701
Virginia, Norfolk 23510
Washington, Seattle 98104

test. Already you have the basic electronic theory; just a little more study will prepare you for the license.

For example, just acquire either the "Second-Class Radiotelephone License Handbook" #21111 or "First-Class Radiotelephone License Handbook" #21144 by Howard W. Sams and learn the additional technical information and the laws necessary for the examination.

When you think you are prepared, send the required examination fee and a filled-out FCC form 756 to the Engineer In Charge at the FCC field office that serves your area. A list of the 31 offices is included in Table 1. Consult the telephone directory for the complete address. All field offices give the tests at least once a week, but some do more often. So, ask the specific office for information before you go there. The fee for either examination is \$4, at this time.

If you don't have a licensed technician, and are forced to recruit one from outside, expect to pay \$10,000 per year (and up) for a good technician.

Test Equipment

Many items of the general-purpose test equipment you now have can be used also for CB servicing. However some specialized equipment for measuring frequency and power will be necessary. Table 2 shows my suggestions for CB equipment, and it assumes you have none to start. Several of the items are inexpensive.

Frequency measurements

The most important piece of test equipment is one for measuring the transmitted frequency. Tolerance for CB is .005%, or 50 Parts-Per-Million (PPM), and the rule requires the frequency-measuring instrument to have 5 times the accuracy that's specified for the maximum allowable tolerance. Therefore, an accuracy of .001% (10PPM) is needed for CB work.

Anticipate the future, before you buy a frequency meter. If you stay with CB service, a frequency counter in the \$300 price range is sufficient. But if you go on to commercial two-way service, expect to spend

between \$1,000 and \$7,000 for a frequency meter.

Out-of-tolerance frequency operation is quite common in CB transceivers. Many modern sets use frequency-synthesis to generate the full 23 channels. Therefore, if one channel has a wrong frequency, expect to find several others. That's why a routine bench check should include measuring the frequency of the transmitter on all 23 channels.

Measuring modulation percentage

In CB servicing, the quality and percentage of modulation often is overlooked. I prefer to observe the transmitted audio by using a scope. If you have a scope that is flat in response to above 27 MHz, it can be used to look directly at the modulated RF output of the transmitter.

On the other hand, there are methods of using a narrow-bandwidth scope by connecting it to the detector output of a short-wave receiver or a modulation meter. The modulation meter need not be elaborate or expensive. Antenna Specialists offers one for less than \$40. Another source of the detected modulation is from a combined wattmeter/dummy-load unit. Again, the best equipment for you depends on whether or not you go on into commercial two-way radio servicing.

Signal generator

Rapid and accurate servicing of receivers demands a signal generator that has calibrated output level, and is reasonably free from drift. The actual frequency can be read by a digital counter. A used Measurement Model 80 generator often can be purchased for \$200 and up.

Sensitivity of the receiver is of extreme importance in CB equipment, partially because of weak transmitter powers. If specs call for 1-microvolt sensitivity for 10dB signal-to-noise ratio, then 5-microvolt sensitivity would permit reception only of strong signals. The generator should have a calibrated output level adjustable between .1 microvolt and 100,000 microvolt.

Meters

Of course a VTVM or VOM can



These are examples of specialized CB test equipment. At the left is a Motorola frequency and modulation meter with digital readout of frequency. Above it is a Heath sine/square audio generator, and at the right is a Cushman Model CE-5 communications monitor for checking both frequency and modulation.

Table 2.
CB TEST EQUIPMENT

- Frequency meter or counter
- AM modulation meter
- Calibrated AM signal generator
- RF voltmeter (digital)
- Oscilloscope
- Field-strength meter
- Wattmeter/dummy load
- Audio generator
- Audio wattmeter
- 12-volt regulated DC supply (adjustable)
- Digital VOM
- Monitor receiver (general coverage)
- Complete set of Howard W. Sams CB Service Manuals

be used for many DC voltage measurements. And an external diode-type RF probe used with a VTVM will give relative readings, but the measurements are not calibrated.

An ordinary field-strength meter can be used for cheap-and-dirty signal tracing in a transmitter. Remove the tip of the collapsible antenna and make a probe out of it. Hold the meter in your hand while touching the probe to appropriate points of the circuit. Although the readings are only relative, it's easy and fast to locate a dead stage by using this method. I don't advise doing the technique with tube sets because of the higher voltages.

The ultimate of measurements comes from a digital VOM that has an RF probe (such as the Fluke Model 8000A). Not only are digital readings more accurate and without any parallax reading errors, but there's never a doubt about the scale and where the decimal point should be. After you've used one for a time, you'll probably wonder why you waited so long to buy it. With the RF probe, stage-by-stage tuning of the transmitter becomes a helpful reality.

Audio generator and wattmeter

An audio signal, usually a sine wave, from a generator is fed to the audio input during the transmit mode so the modulation level and

distortion can be measured. An inexpensive generator can be used if it has low-distortion output. A separate audio generator is not necessary if the RF signal generator has a built-in audio source with a jack to bring it out.

I believe in the use of an audio wattmeter for rapid and accurate servicing. For example, often a manufacturer will list the wattage of audio output which should result from an input RF signal of a certain level and modulation. With the proper equipment, such a test is fast, and it gives the sensitivity in one easy measurement.

Other uses include signal-to-noise measurements, which are beyond the scope of this article.

Output wattages can be measured without any special equipment if you assemble a dummy load from non-inductive resistors totaling the rated impedance with sufficient wattage dissipation. Connect the dummy load (instead of the speaker) to the receiver output, measure the AC voltage across the load, and calculate by this formula: output power equals the voltage squared, then divided by the load resistance.

Power supply

The ideal power supply to operate CB radio transceivers during branch tests should be both **regulated** and **adjustable**. Regulation is needed because of the large change of current from receive (.1 ampere) to transmit (3 ampere). Without regulation, the voltage would change excessively during transmit/receive cycling.

Transceivers can develop peculiar troubles that are triggered by certain high or low supply voltages. In an auto, the voltage applied to a radio might vary from 11 volts up to 16 volts. Therefore, it's desirable to be able to vary the power supply over this range to check the action of the radio regulator circuits, and check the breakdown points of the protective diodes.

For example, I've serviced equipment that would blow fuses, but gave no other symptoms of a short circuit. By using an adjustable-voltage supply, I was able to set the voltage to where I could locate the short without popping the fuse.

A 12-volt car battery, of course, can be used if you install a trickle charger. Unfortunately, there are problems of corrosion, and the charger often makes the radios hum. Some shops turn off the charger during critical measurements.

Service data

One item that causes untold grief

Table 3. CB TEST EQUIPMENT MANUFACTURERS

EICO

283 Malta St.
Brooklyn, N.Y. 11207

Hickok

10514 Dupont Ave.
Cleveland, Ohio 44108

Fluke

P.O. Box 7428
Seattle, Washington 98133

Heath

Benton Harbor, Michigan 49022

B&K

1801 W. Belle Plaine Ave.
Chicago, Ill. 60613

Measurements

Grenier Field
Manchester, N.H. 03103

Motorola

1313 E. Alagonquin Rd.
Schaumburg, Ill. 60172

Cushman Electronics

830 Stewart Drive
Sunnyvale, Calif. 94086

Hewlett-Packard

1501 Page Mill Road
Palo Alto, Calif. 94304

Lampkin Laboratories

P.O. Box 9048
Brodenton, Fla. 33506

Singer Instrumentation

5340 Alla Road
Los Angeles, Calif. 90066

Antenna Specialist

12435 Euclid Ave.
Cleveland, Ohio 44106

and wasted time is the lack of good service information. The best source of data is the Howard W. Sams CB service manuals. If you do warranty service, the manufacturers will furnish service manuals. However, with the exception of E. F. Johnson manuals, the Sams information is vastly superior.

Repair parts

Most of the major manufacturers give excellent parts service. But the Japanese brands create most of the hair-pulling crises. The imported radios often appear under many private labels. Luckily, you soon learn that many of the parts are interchangeable between brands.

Don't overlook the many sources for replacement transistors. Check the cross-reference guides of the various brands; most solid-state devices you need will be listed.

To keep costs reasonable, it's probably best to obtain crystals for the synthesizer circuits from the manufacturer of that brand of CB radio. Although, Sentry will supply crystals for most models.

Additional Profit

In addition to profit from your sales of labor and parts for repair jobs, two other general sales efforts can help the jingle of your cash register. They are sales of CB radios, and sales of accessories.

Perhaps you're not inclined toward selling the radios (because of competition from discount houses, or other reasons). But accessory sales can be a gold mine. In addition, prices and installations are no problem.

CBers are notorious for changing antennas, and this makes antenna sales a fast-turnover sideline. When the word gets out about a new antenna of superior performance, many of the CBers can't wait to get one. Companies such as Antenna Specialists, High Gain, Newtronics, and Avanti can give you details on their antenna products.

Along with antennas, you should stock coaxial cable. And this should not be bargain-priced. The avid CBER must have the best. Coax connectors also should be stocked in depth.

The do-it-yourself CB instal-

lations result in many wrongly-installed connectors and a flood of shorted cables. You either can install the new cable and connectors, or sell them to the CBER.

In fact, you can sell a ton of these parts, without any problems of installation, just by advising them what they need. For example, one CBER complains about alternator whine, so you sell him a "whine" filter, which he installs. Another asks how he can know if his radio is transmitting properly; you recommend a field-strength meter to be mounted on his dash or used at home. If a customer wants to know about his power and modulation, sell him a modulation meter and wattmeter. Sell another customer an elaborate microphone for his base station. The list could go on and on. The key is that **you** are the expert who can recommend items to please the CB owner, and who can make a profit from the sales.

Two-stepping

No, that's not some kind of a dance, but a different kind of distribution pattern. When the CB business was young, the manufacturers sold directly to the dealers, without a distributor in between. As the sales increased, some of the newer sellers didn't want to stock very many radios at a time. So they approached the original dealers, who sold them small quantities at an intermediate price, without any limitation on how few were purchased at a time.

At the present time, two-stepping is a highly competitive business, and usually you can receive a good discount. However, the shortage of radios has slowed the supply somewhat.

Hide The Technicians

Keep the service area and the technicians away from direct contact with the CB customers. This minimizes wasted time from the customers who want long conversations with the techs. Let your customers know their business is appreciated, but be professional in your approach so as to discourage idle chatter. Notice the phrase was "idle chatter", for it is right and

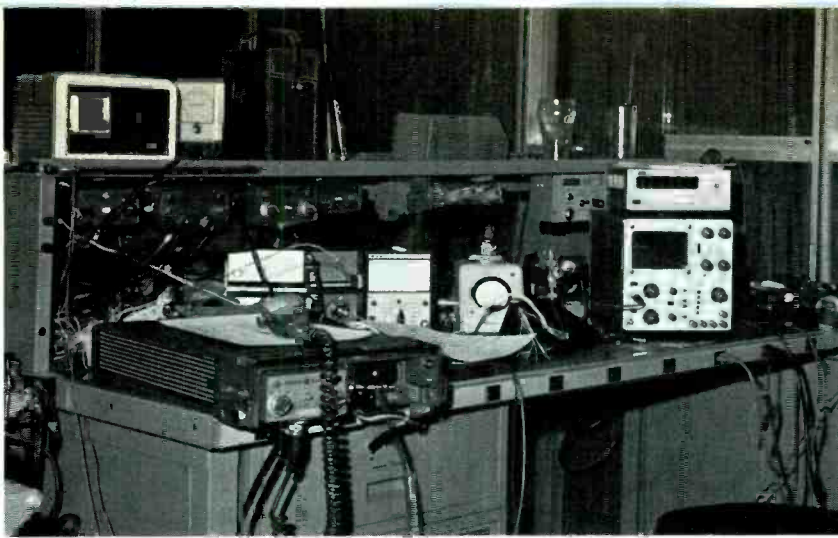

Remote-control heads for models this dealer sells are fastened to the bottom of the top shelf, so it's not necessary to remove the heads for chassis repairs. At the upper left is a battery charger, a dual-trace scope and digital VOM are at the right. In between are other items of test equipment, and a transceiver for repair.



These racks of repaired CB equipment show the volume of business that's possible.

profitable that you give the customers specific bits of information so they can buy with confidence the items of equipment you advise. Remember, you are the logical source of technical advice.

Sometimes Say "No"

When a new CB shop opens, the first units brought for service quite often are the "dogs". That is, units that have been butchered by incompetent shops or by the owner.

Some of these radios will be of the inexpensive variety which are not worth repairing. You must learn when it's expedient to turn down business. If it's not profitable, don't service it.

The CB Universe

"How much CB service will be needed during the next few years?" "What is the long-range future of the CB business?" These are important questions to be answered before you start any kind of CB business.

No one knows for certain how many CB units are in use. The hand-held walkie-talkie types never were licensed, and many owners don't bother to obtain a license (gambling that the understaffed FCC won't track them down). However, it has been estimated that more than 6 million CB units now are in use, and that about 1 million more will be sold in 1975.

Other estimates are that one of every five trucks, one of seven recreational vehicles, and one of every thirty cars **now** are CB equipped.

The Federal Communications Commission (FCC) is considering sweeping changes, including the addition of a new band. Just recently, the strict (but often-ignored) ban against making a hobby or imitation amateur band of CB has been eased. Even the use of "handles" (nicknames) is not banned just so long as the legal call letters are used at the beginning and ending of each communication.

The phenomenal growth of the CB business, even during times of recession and inflation, is the wonder of this decade. Factories manufacturing CB equipment are running at full capacity, and neither distributors nor dealers have any backlog of unsold merchandise.

Panasonic has announced plans to have models of their new CB line ready by January of 1976, and several giants of the American TV makers are watching carefully the growth of CB with the possibility they will produce CB radios.

Although there is some uncertainty because the FCC has not announced the potential changes of frequencies and bands, almost everyone in all levels of the CB business believes the growth will continue unchecked.

All indications point toward this as an ideal time to add CB service as a sideline to TV repairs, or to change completely to a sales and service business for both business and CB radios.

Advertising

Here are some of the ways to make known your new CB service:

- Place a "CB Radio Service" sign in your window;
- Advertise under "CB Radios For Sale" in the classified columns of your local newspaper (many Cbers read such columns regularly);
- Add a tag line to your radio commercials;
- Ask your customers to recommend you to other CB owners; and
- Place an ad for "CB Radio Service" in the telephone yellow pages. □

cartoon corner



"I'm tired of looking poor every time a serviceman calls."

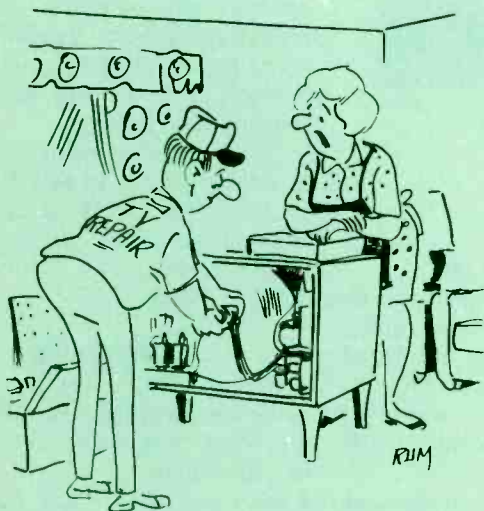

"You've said Hmmm five times— what does that mean billwise?"



"I was once in this business— never refused credit to anyone."

Forest H. Belt's EIGHT-TRACK WORKSHOP

Session 1/Conducted by Dewey C. Couch

Eight-track cartridge tape machines are very popular for both home and auto use. The music quality is excellent, and the operation is quite convenient. However, many of them need adjustments or repairs.

This is a good service market for you, but you can't use a logical and speedy servicing approach unless you truly understand how the mechanisms work.

As we have pointed out in previous Workshops, the whole servicing job can't be done simultaneously. Instead, experienced techs divide the mechanical servicing into **five** phases: cleaning and lubricating; inspecting, testing, adjusting, and diagnosing. Cleaning and lubricating are covered in Session 1. Also, these steps eliminate many faults without any further testing. Follow all the steps shown; they can save you many callbacks.

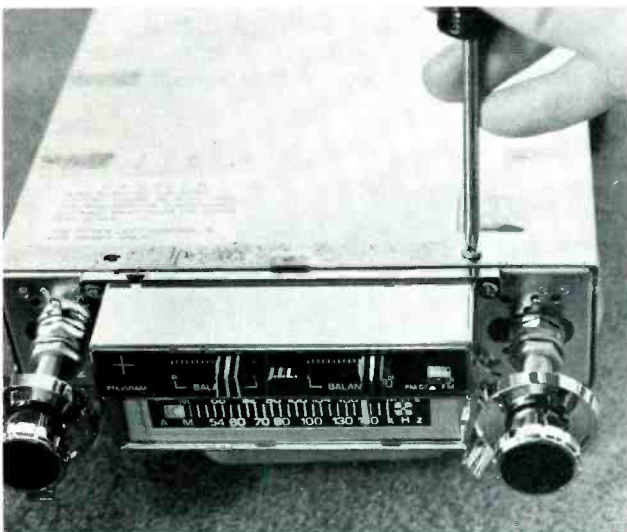

Step 1. Before you can service any kind of mechanical gear, you have to gain free access to the parts and assemblies. Automobile eight-track players fit in metal housings that mount in or under the dash panel. With in-dash units, once you have them out of the car, you expose the mechanism by removing top and bottom covers. Universal types usually slide out the front of a metal cabinet, after you've removed a few screws. Watch out for hidden wires and cables as you disassemble; you might pull something loose.

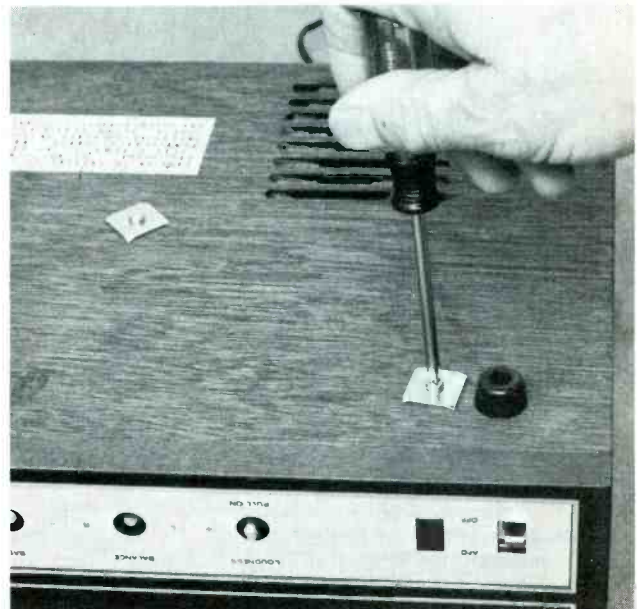

Step 2. Most home-system eight-track decks and modular units also slide out the front of their cabinets. Turn the machine upside-down on a soft, clean mat (Handi-Wipes are reusable, soft, and inexpensive) and remove the four-or-so mounting screws. Be certain no screws or tools slip under the cabinet; they mar the finish. Return the cabinet upright and slide the mechanism out.

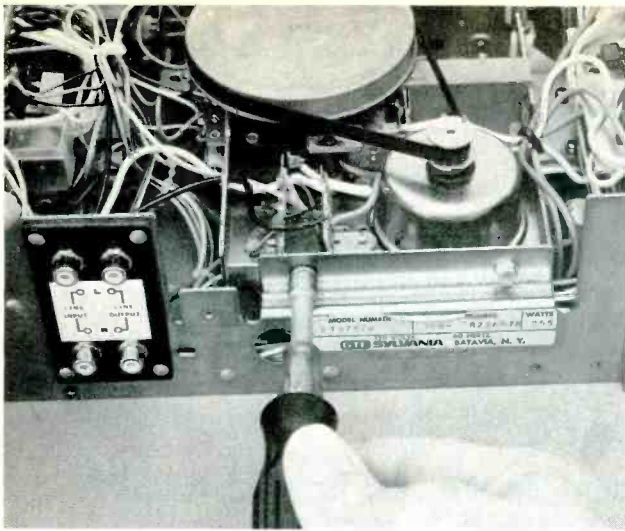

Step 3. Pulling the mechanism out of the cabinet might not be enough, especially if the unit is part of a tape/radio system. Several mechanical parts and linkages still could be concealed by the main chassis. Study the frame carefully to see how it is put together. Most mechanisms in machines of this type fit between front and rear chassis frames. Remove front and rear mounting screws and lift the mechanism clear. You might have to lift one side or the other and turn the mechanism over. For complete removal, you might have to take apart connecting wires and cables. SKETCH wire connections first. Masking tape makes handy wire identification tags. Wrap a strip around the ends of each wire as you take it loose; mark the tape to tell you where the wire reconnects.

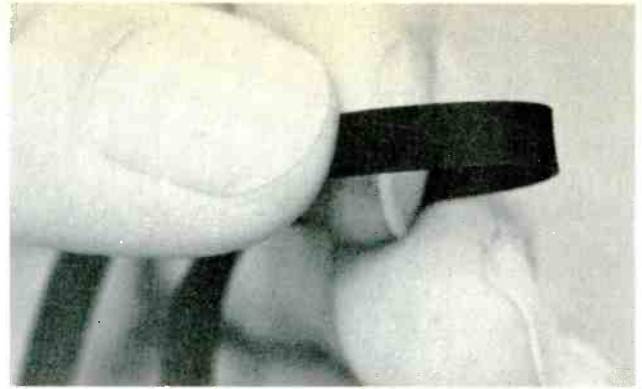

Step 5. Take a good look at the belt. If it shows any sign of wear or cracks (even minute ones), install a new belt. You don't want callbacks.

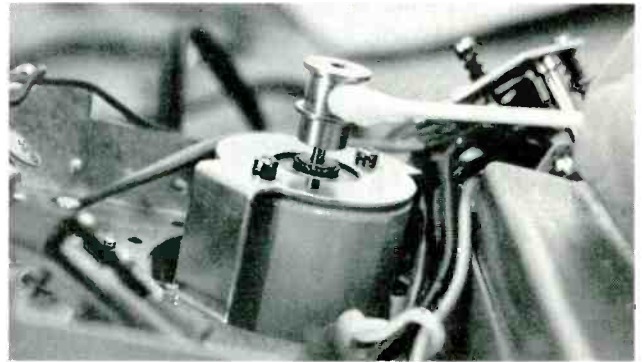

Step 6. A clean belt doesn't do the whole job. If the motor pulley is dirty, you can still find slippage between the pulley surface and the drive belt (that's where most belt slippage occurs). With the belt removed and the motor running, dip a Q-Tip in alcohol and hold it against the pulley. The eraser end of a wood pencil makes a handy, safe tool for actuating the motor-power switch. Look closely at the pulley as it spins. The faintest trace of wobble means the motor shaft is bent. The cure is a new motor. Don't let it pass just to save money.

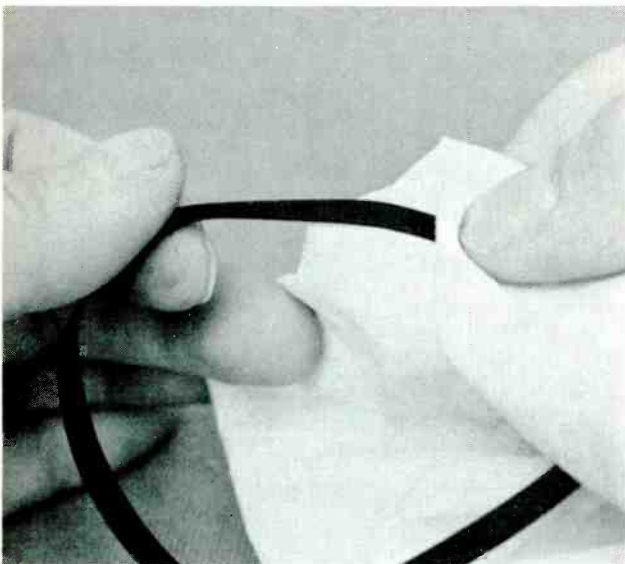

Step 4. Tape in eight-track machines must travel at exactly 3-3/4 IPS (inches-per-second). To maintain that speed without any variation, it's imperative that the flywheel drive belt be clean and dry. If the belt is dirty, or even slightly oily, tape speed becomes erratic. You hear the phenomenon called **wow**. The tape might not transport at all. Just for maintenance, always remove the belt and clean it thoroughly with isopropyl alcohol. DO NOT buy alcohol that contains additives such as winter-green oil, glycerine, etc. The alcohol evaporates and leaves the additives on the belt, resulting in belt slippage later on.

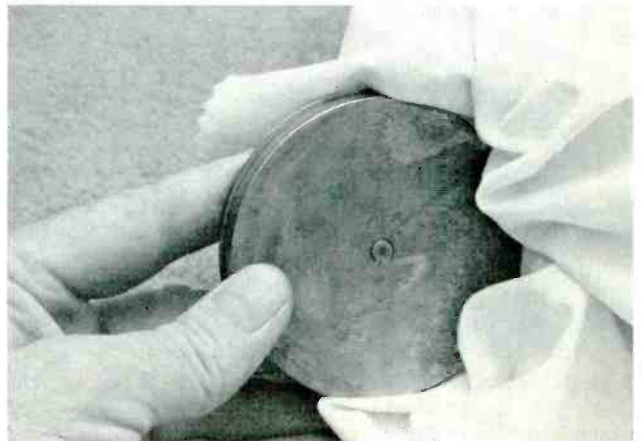

Step 7. A dirty flywheel might not always be the direct cause of belt slippage, but the grime can contaminate the belt. Use a clean cloth or Handi-Wipe, dipped in alcohol, to clean the outer rim. Don't touch the driving surface after you've cleaned it. A tiny amount of body oil from your fingertips can contaminate the belt, and that causes slippage.

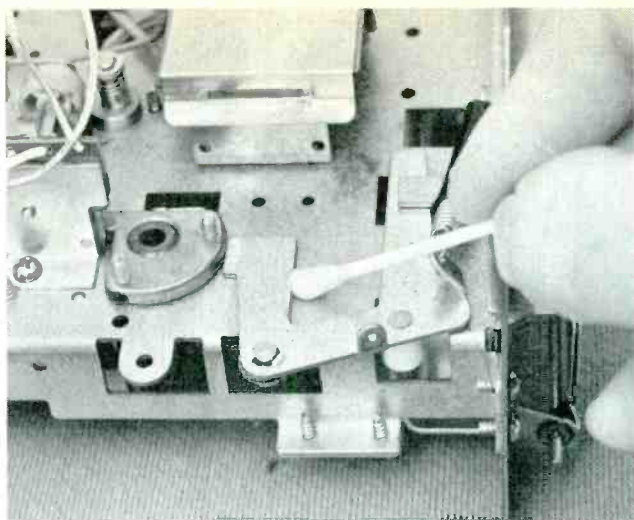

Step 8. Certain lubricants dry and harden around the edges and surfaces of levers and slides, eventually making them bind. Alcohol will cut the layer. Use a Q-Tip to probe into hard-to-get-at corners. Clean all the levers and slides in any machine you service, and clean the surfaces they come into contact with.

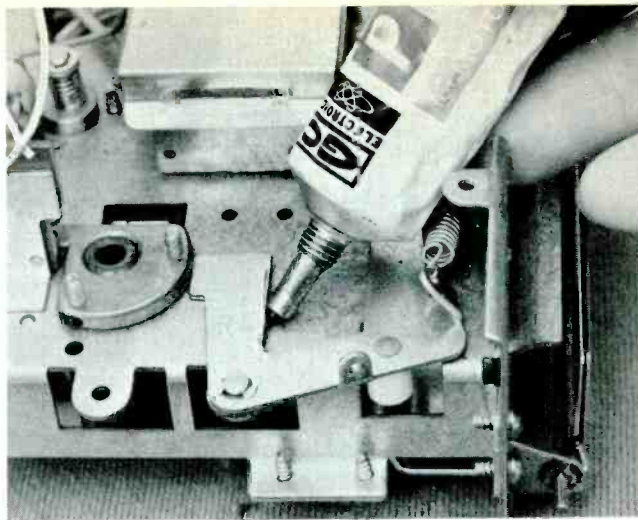

Step 9. After you've cleaned the levers and slides, apply a thin layer of grease to all contact surfaces; Lubriplate and Phonolube are excellent. Use lubricant sparingly. DO NOT use graphite; it migrates and ultimately contaminates other parts and assemblies.

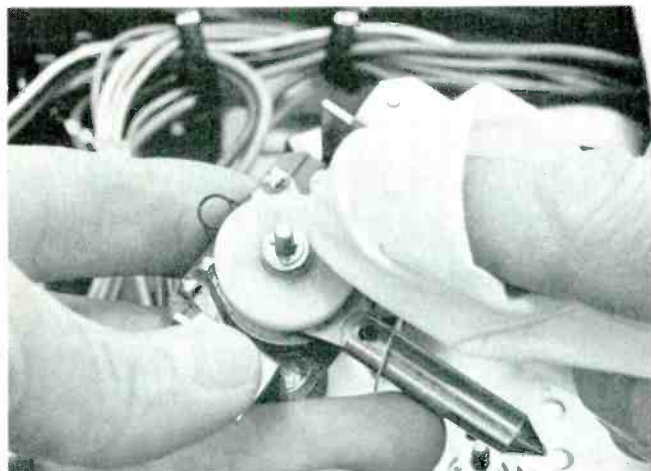

Step 10. Dirty or hardened lubricant on the track-selector cam and ratchet pawls might lead to a malfunction in the channel-selector mechanism. Remove all grease from the cam and pawls. A Q-Tip and alcohol will do the trick. After cleaning, apply a dab of lubricant to the ratchet and step surfaces of the selector cam and to the ratchet pawls. Again, don't over-lubricate; small dabs of grease go a long way.

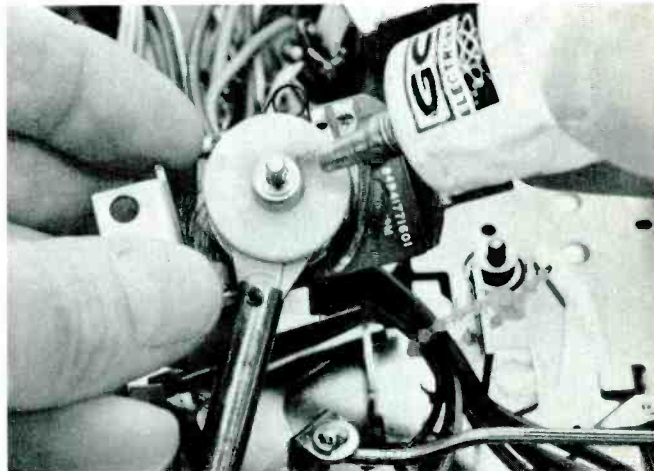

Step 11. Most eight-track machines have various shafts that move up and down in bushings. The basic shaft (the mechanical link between selector cam and head plate) and the headplate lifter shaft are examples. If either one binds, the machine changes channels erratically, or not at all. Remove the head plate and clean the shafts and their associated bushings thoroughly. A pipe cleaner forms a dandy tool for cleaning small bushings such as these. Apply a very thin layer of lubricant to the shafts before you reassemble them in their bushings.

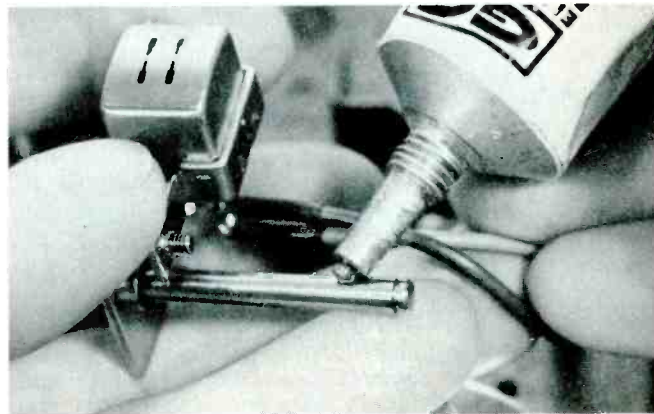

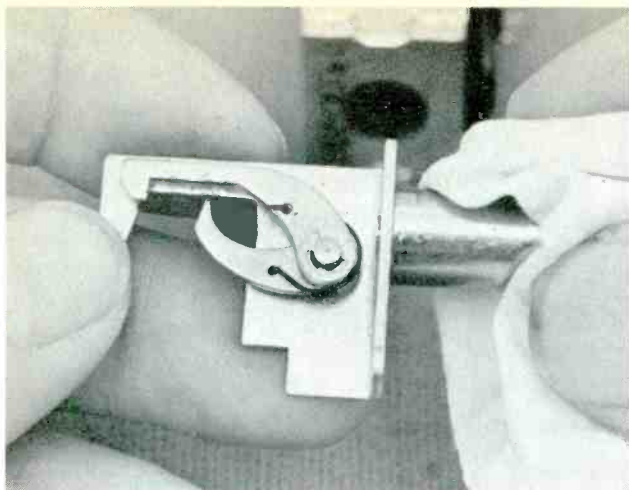

Step 12. The plunger in the track-change solenoid seldom binds. But it pays to be thorough in your cleaning. Remove the plunger and wipe it clean. If necessary, use a clean cloth and alcohol to cut any dirt or grease layers that have accumulated. **DO NOT** lubricate the plunger. It should always be clean and dry.

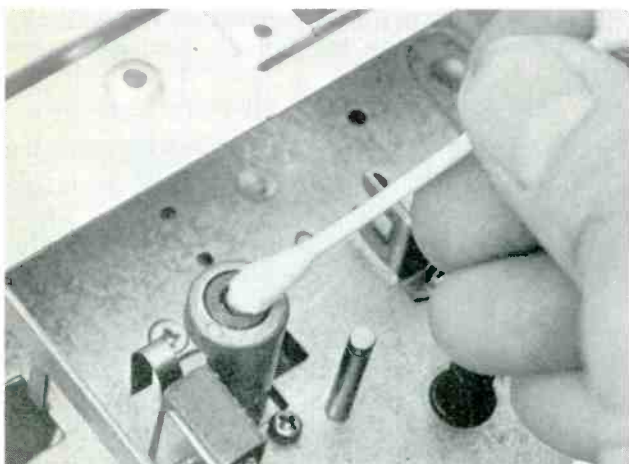
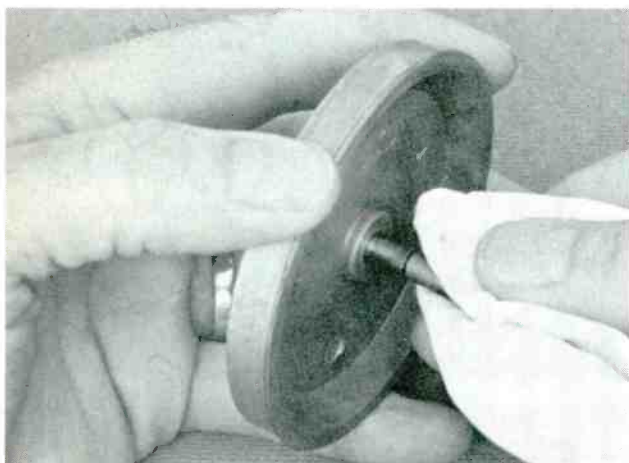

Step 13. A recurrent problem arises from build-up on the capstan of oxides scraped from the tape. Slippage results. Wow and flutter are the symptoms. Remove the flywheel, then clean the capstan and its bearing. Most capstan bearings need no lubrication; it is inside the bearing material. **DO NOT** lubricate the capstan. And **DO NOT** touch it with your fingers after it has been cleaned.

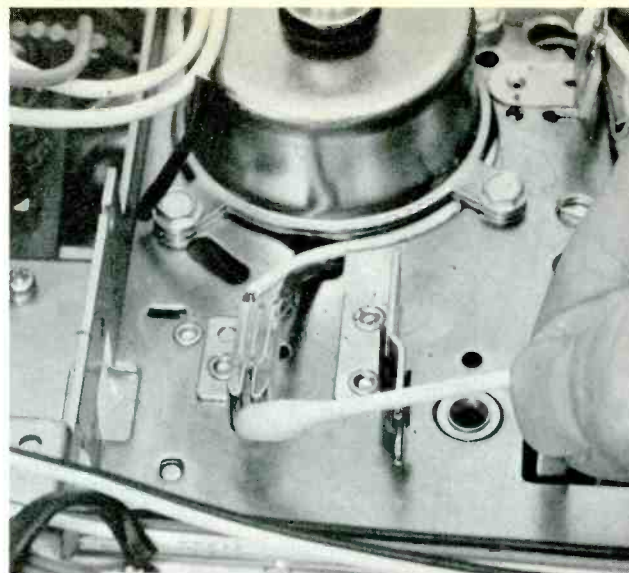

Step 14. You also can trace certain malfunctions in the channel-selector system to oxide deposits from the tape. Oxide dust builds up on the change-sensor contacts. It traps oil, and the scum insulates the contacts from the metal foil on the tape. A Q-Tip and alcohol remove the film. Do not scrape the contacts with any metal object; you might scratch the smooth contact surfaces, resulting in excessive tape wear.

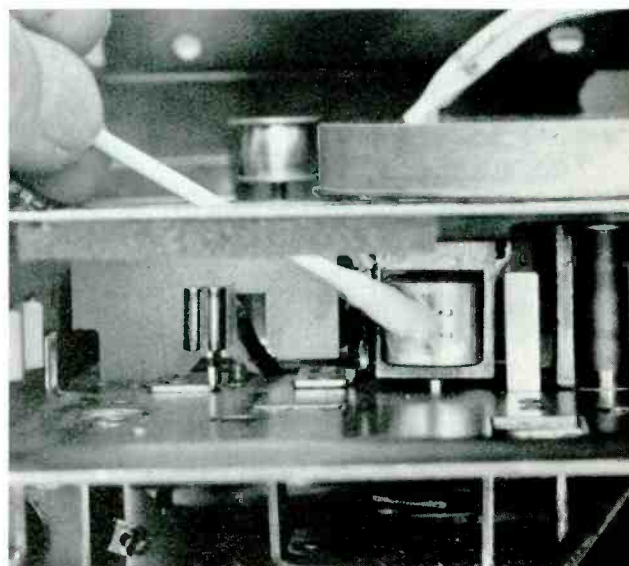

Step 15. The head can be considered the heart of any eight-track player/recorder. It deserves special attention. Oxide build-up is one of the worst problems. Oxide deposits separate the head (partially, at least) from the moving tape, causing a number of symptoms: low or fading playback volume; erratic recording (if the unit records); audible squeaks; noisy playback, with lack of brilliance; and undue tape wear. I prefer not to use any type of head-cleaning cartridge. They become abrasive after a few passes, and may damage the smooth head-face surface. Use a soft cloth, saturated with alcohol or some good-quality head-cleaning solution (CMC is good). As I said earlier, be sure the alcohol you buy has no additives. These substances migrate. Sooner or later, they pollute the capstan and sensor switch, and damage the tape. Head-cleaning solutions should be free of any oils, for the same reason. Never use any kind of head "lubricant" after cleaning.

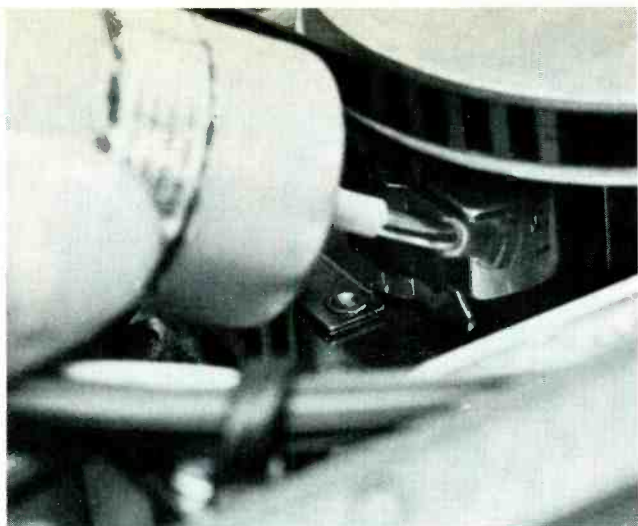

Step 16. When you've finished cleaning and have everything reassembled, degauss the head. It holds residual magnetism from the tape and might have picked up magnetism from metal tools you have used near it. Make this degaussing a regular step in your servicing procedure. Turn your demagnetizing tool on and hold it close to the head face. But don't let the tool touch the head. Move the tip in a circular motion about the head. After several rotations, move the tool at least two feet from the head before you turn it off. Otherwise, the head might be remagnetized by the collapsing field.

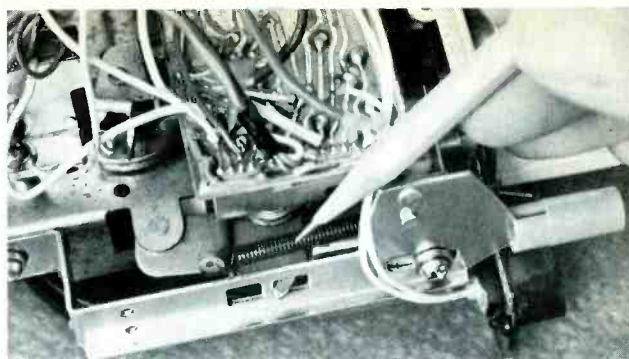

Step 17. Visual inspection often uncovers faults that were not helped by cleaning, or that perhaps were caused during the cleaning process. Look the mechanism over thoroughly. Check for springs that might have been knocked loose. Be sure all wires and cables are solidly connected and dressed so they don't interfere with movements of mechanical parts. Watch for bent levers and slides. In other words, inspect everything you can see. Correct any defects you find before you proceed.

This concludes the first of three sessions about eight-track machines. You know proper cleaning and lubrication, and what to look for during a visual inspection. Next month, in Session 2, we'll explain the three other phases of the servicing procedure: tests, adjustments, and diagnosis. □

The Eight-Track Cartridge

Eight-track tape cartridges (sometimes called Stereo-8) all conform to the specifications of the original Lear-Jet cartridge. The endless tape is wound on a single internal reel, and the tape does not leave the cartridge. Three cutouts at the rear of each cartridge allow the track-change contacts, playback head, and capstan drive to protrude into the cartridge, making contact with the tape.

Four sets of stereo tracks are recorded on each tape, making necessary some kind of mechanism to select the desired track. A strip of metal foil is attached to the tape at the point just preceding

the start of the music, and it shorts between two contacts to act as a switch that starts the track change. Each time the foil closes the circuit continuity, the mechanism moves the playback head to the *next* set of stereo tracks. Most machines also provide a manual-change switch.

All the tape is wound on a single internal reel, with the tape leaving at the hub (inside of the tape pack) and arriving at the outside. No power is applied to the reel. When the cartridge is inserted into the player, the capstan of the player mechanism contacts the pressure roller that's a part of the cartridge, pinching the tape in between. This is the only power that is applied to the cartridge. Also, the internal spring-mounted pressure pads keep the tape tight against the head and the track-change contacts.

Rotation of the capstan and roller pulls the tape from the center of the pack on the reel (by way of the head, track-change contacts, and the corner guide pin). That rotates the reel, which in turn winds the tape from the capstan around the outside of the pack on the reel. The tape is a special kind, designed for minimum friction; each layer of tape slides against the next layer.

Because there are eight narrow magnetic tracks on tape that is only 1/4-inch in width, extreme accuracy of cartridge and head positions must be maintained to prevent crosstalk (music of one track being heard faintly on another).

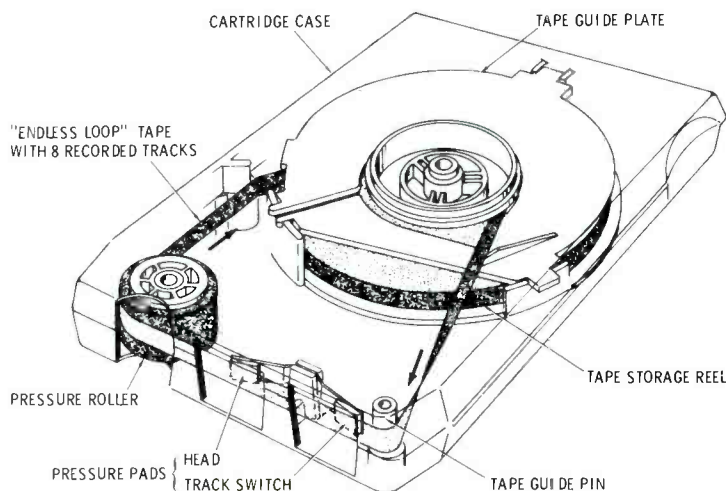

Courtesy of Howard W. Sams,
from 1-2-3-4 *Servicing Automobile Stereo* by Forest H. Belt.

DON'T GET STUCK WITH THE TAB.

**Do your Christmas shopping before
midnight Nov. 30th.**

If you've been saving Sylvania tube tabs, your time has come.

Unless your tabs are received at award headquarters by midnight Nov. 30th, all you'll have is a bunch of tabs.

And that includes those color picture tube labels that are worth 20 receiving-tube tabs.

But before that magic hour you can have anything in the '75 Save-a-Tab catalog.

After midnight your tabs will be as valuable as Cinderella's pumpkin.

Do your Christmas shopping now for everyone (especially yourself) from the catalog available at your Sylvania distributor.

But have your tabs at award headquarters by midnight Nov. 30th.

Nov. 30th, the world.

Dec. 1st, just tabs.

GTE SYLVANIA





SYLVANIA
electronic tube

YOUR CHOICE
TUBES
MILITARY
TUBES

TUBES

SYLVANIA
electronic tube
6X4
6X4

SYLVANIA
electronic tube
6X4
6X4

Servicing stereo audio systems



Part 2

By J. A. "Sam" Wilson, CET

Noise and distortion are undesirable in an audio system. They can't be reduced to zero, so the goal is to minimize them enough that they won't be noticed by the listeners. This time, noise is the main topic. Some of the material defines the types of noise, and it serves as a review for part of the Audio CET Test.

Servicing audio systems seems simple. You work to decrease noise and distortion, and you try to increase gain, frequency response, and output power. In practice there are tradeoffs that make it impossible to achieve all of these goals at the same time.

Gain versus bandwidth

Anything you do to increase the gain of an amplifier automatically reduces the bandwidth. A straight piece of wire passes the entire audio spectrum of frequencies, but its gain is only 1. From that point, increasing the gain narrows the bandwidth. At first, the solution seems to be plain: reduce the gain per stage and use more stages.

Noise versus the number of stages

The amount of noise generated in a system increases in step with the number of stages. In other words, more stages produce a poorer signal-to-noise ratio. The problem is related to the next tradeoff.

Noise versus bandwidth

Noise originating in an amplifier increases with temperature, and it also increases with a wider bandwidth.

Gain versus noise

Anything you do to increase the

gain of an amplifier also increases the noise. On the other hand, degenerative feedback reduces amplifier gain while it improves the bandwidth and decreases the noise.

These general observations assume that noise is just one thing, coming from one source. That's far from the truth. Noise can originate outside of the audio system, it can appear in some of the input sources brought to the main amplifier, or it can originate in the amplifier stages. In fact, it seems noise is natural.

Record Player Noise

Noises coming from record players can be grouped roughly into two categories: physical noise and electrical noise. Mechanical vibrations of stylus and cartridge, while the record is playing, can be heard as a scratchy noise along with tinny-sounding music. Sometimes this is called "needle talk".

Dirt

Dirt in the record grooves causes hissing, scratching, and popping noises. Incidentally, the dirt isn't removed by the addition of a small brush mounted in front of the cartridge. And some record-cleaning cloths might remove some dirt, but leave a sticky coating that attracts and holds particles of dust and dirt.

Static charges on the plastic of the record tightly hold these particles, making removal very difficult. Perhaps the best solution is to use one of the new cleaning machines that also removes the static charges.

Record defects

Irregularities of the record groove walls causes various kinds of noise. One kind, called "mold grain", is an irregular surface that is produced at the time the record is pressed. If you use a microscope, you can see it in the unmodulated grooves at the beginning or end of the record. Mold grain also is known as "orange peel" because that's the appearance when seen on the flat portions of the record near

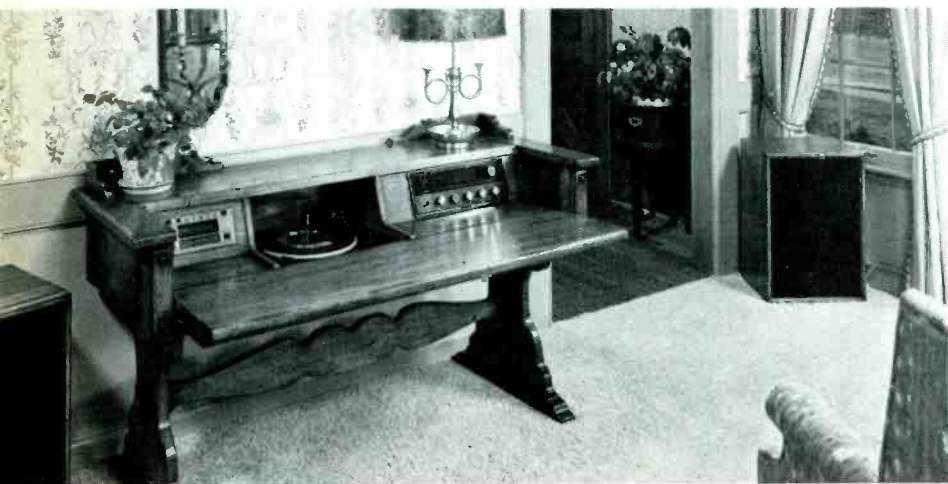

Model 6824 stereo console by Magnavox has an AM/FM-stereo radio, record changer, and an 8-track tape player in a hinged-drop-top cabinet. Speakers are external. (Courtesy of Magnavox)

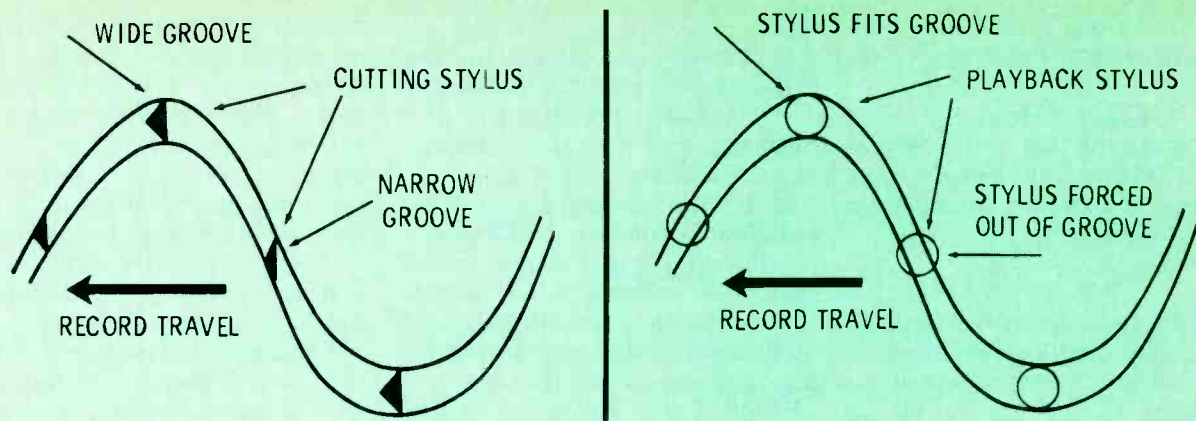

Fig. 1 Tracing distortion of phonograph records is caused by the flat edge of the cutting needle during recording. The groove narrows when the stylus moves sideways rapidly, and the playback stylus can't always remain in the proper part of the groove.

the center.

Worn spots in the groove cause the stylus movement to produce spikes in the signal, and these pulses might sound like pops or ticks if they are separate ones, or a series of closely-spaced spikes might appear as a hiss.

Defective cartridges or worn styli seem to emphasize noises and distortions. Linkage between the stylus and the element might be broken or displaced, or the ceramic element could be chipped or broken. Sometimes it's as simple as a stylus that is not wedged solidly in the yoke of the linkage. Styli and cartridges are subject to much abuse by the operators of stereo systems, and they should be the first thing checked.

If the noise from a record seems to be excessive, gently lift the tone arm. Any noise that remains is from poor shielding or a defective amplifier. Other noise could be from the cartridge or the record. Substitution of one or both should prove the source.

Tracking of the stylus

According to the compliance of the stylus assembly, every phono arm has an optimum pressure (called "tracking force") between stylus and groove. Too much tracking force (weight on the stylus) produces excessive wear of the record groove. But too little tracking force might permit the stylus to bounce from side to side or up and

down in the groove. In extreme cases, the stylus can jump out of one groove into the next.

I remember many years ago, when a certain Ken Griffin 78-RPM record was popular, that some cartridges with poor compliance would skip grooves with every deep organ pedal note. Modern cartridges track much better, but a stylus that's careening around in the groove can create sounds similar to noise.

Most of the better-quality phono arms have an adjustment for setting the stylus pressure. Don't underrate this adjustment, it's important. There must be a dozen gimmicky ways of setting stylus pressure without using a gauge. One simple way is to use a dime as a weight or a counterweight to determine if more or less pressure makes the music sound better. Another is to decrease the stylus pressure until distortion develops, then increase it somewhat.

After some experience you might be able to do an acceptable job of pressure adjustment, but **don't** try these shortcuts in front of customers. Stylus-pressure gauges are not expensive. Be professional, buy and use one in your repairs.

Lateral-tracking error

Ideally, the sideways motion of the stylus always should be at right angles to the groove. That's the purpose of mounting the cartridge at an angle to the remainder of the

arm. Any deviation from perfection is called "lateral-tracking error". Usually it is not adjustable, except by positioning the mounting point of the tone arm, and that isn't always possible.

Lateral-tracking error changes as the arm moves across the record; therefore, one test is to notice any increased distortion or noise that occurs where the tracking error is the worst.

Tracing distortion

A recording stylus must have a flat side to cut the groove, and when the stylus is required to move sharply to one side, the width of the groove is narrower. A playback stylus is round or elliptical in shape. So when the tip reaches a narrow point of the groove, the stylus is lifted higher. In extreme cases, the stylus can jump entirely out of the groove (see Figure 1).

Distortion is produced by this undesired vertical motion or groove jumping of the stylus, and it is called "tracing distortion".

Tape Noises

Tape playback equipment has fewer sources of mechanical noises than disc players do. But one serious noise is the squeal from improper contact between tape and head. This shrill, piercing sound can be caused by any of several conditions. Some individual reels of tape are prone to squeal; and worn or compressed pressure pads oper-

ated at the wrong tension have been known to cause the problem.

Other Noises

By stretching the definition of noise a bit, we can include some additional sounds that detract from listening pleasure.

Flutter

A rapid variation in the speed of either tape or discs produces a sound called "flutter". Sometimes it appears to the ear to be an amplitude variation. The key word is "rapid" variation, meaning several times a second. Such variations most often are caused by minor defects in the drive mechanism; for example, an idler wheel with a dent or a flat spot on the rubber tire.

Wow

An irritating sound called "wow" is caused by slow variations of tape or disc speed. Frequencies of the music are altered, and musicians say the music sounds flat or out of tune. The effect is most noticeable on long-duration sounds and those without natural vibrato, such as piano music.

Wow with records can be seen by checking the turntable speed with a stroboscopic test disc. When wow is present, the lines move backward for part of a revolution, and on-speed or fast for the remainder.

Rumble

"Rumble" is easiest described as a low-frequency noise much like thunder. It is confined to record players, because it originates in an unwanted movement of the turntable that causes periodic thumps or slow vibrations to reach the stylus.

Hum

If noise can be called any deviation from perfect reproduction of audio (except distortion and poor frequency response), then hum is a very undesirable form of noise.

Most hum comes either directly or indirectly from the 60-Hz power. Insufficient filtering of the power supply DC voltages is one source. With tubes, the hum can be picked up by capacitance action because of the nearness of heater and grid wiring. Tape heads or phono cartridges can pick up hum either by electrostatic or magnetic action.

One kind of hum that seems to have no source comes from ground loops or common-ground currents. Look at it this way: suppose the base resistor and drive signal were connected to a ground on one side of the amplifier chassis, and the emitter resistor was grounded at the other edge of the chassis. Now, assume that some 60-Hz current (perhaps from filter capacitors, or the ground for dial lamps) flows between those two ground points. The current flowing through the resistance of the chassis metal will produce a voltage drop, which is connected to the input junction of the transistor. The AC hum voltage is amplified by the transistor just as though it were a desired signal.

Many shielded cables in stereo amplifiers have the shield grounded at only **one** end, to prevent any common-ground currents from traveling through the shield and causing hum.

Microphonics

When they are jarred or struck a blow, some microphonic components produce ringing sounds similar to that of a small bell. Solid-state components almost

never exhibit microphonics. Tuning capacitors in AM or FM radios occasionally are microphonic; that's why most are floated on rubber grommets. Tubes are the big offenders. Tubes intended for low-level operation usually have extra attention paid to the internal bracing, particularly of the control grid, for vibration of the elements is the cause of the microphonics.

You might be surprised to learn that record players can exhibit a type of microphonics. The mechanism, motor, and base plate have a much higher mass than does the arm. Therefore, any jarring of the record player moves the arm more than the turntable, producing an output signal from the cartridge.

A serious problem with microphonics arises when the record changer and the speaker are both in the same cabinet, so the low-frequency tones of the speaker shake the record player.

If there is enough coupling between the two and the bass and volume controls are turned high enough, the result is a loud roar, or low-frequency audio tone.

All record changers and some record players are mounted using springs and rubber grommets to minimize feedback from the speaker. A common mistake is not loosening the mounting screws when the machine is new and first unpacked. If the screws are off center or binding inside the rubber grommets, sometimes it's necessary to remove the mounting screws and let the base plate float only on the spiral springs.

A fast test for both motor noise and microphonics is to place a small block of wood on the baseplate, and lower the tone arm so the stylus rides on the wood rather than on the record. Then turn on the motor, and turn up volume and bass controls. The setting of the volume control where a constant audio tone sounds is the loudest setting you can use without this microphonic howl.

If the speaker and the amplifier have excellent low-frequency response, it's possible to cause the howl even if the record player and speaker are in separate cabinets several feet from each other!

Fig. 2 This waveform of "pink noise" (tube hiss) shows it is not an even and continuous signal, but is made up of many pulses that vary in amplitude and in width.

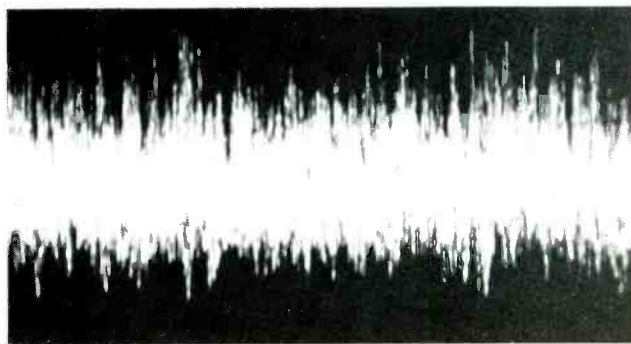

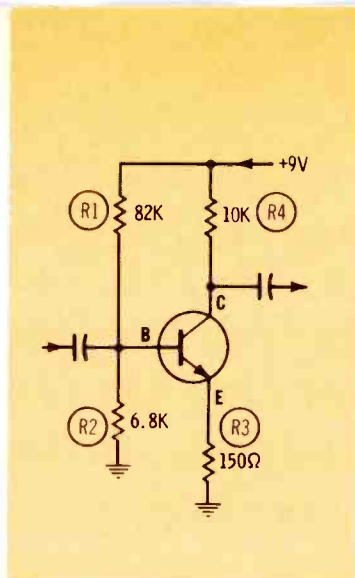
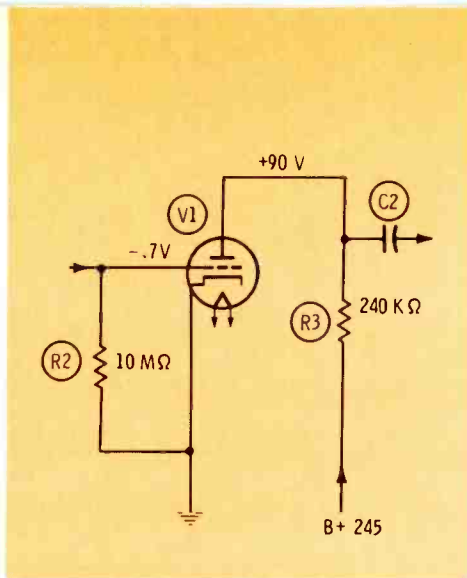

Two things make this audio-amplifier stage prone to excessive noise. Bias is the "contact-potential" type, in which some of the electrons from the cathode randomly reach the grid, making it negative because of the high resistance there. Extra noise results. Also, the 10-megohm resistor generates noise because of the DC voltage across it.

Amplifier Noise

The frequency response of amplifiers and speakers can be measured by test signals called "white noise" and "pink noise". A tuned-band-pass amplifier/meter instrument is used to read the response.

The term "white noise" comes from an optical phenomenon called "white light", which contains all frequencies of visible light. So, in the same manner, white noise is supposed to contain all frequencies of the audio spectrum. Unfortunately, white noise probably is misnamed. White light is made up of unvarying percentages of the visible colors. By comparison, white noise has random audio frequencies that over a period of time tend to include all frequencies. But right or wrong, the term white noise is in common use.

Scope patterns show white noise (Figure 2) as spikes or pulses of different widths and amplitudes. And we know from analysis of pulses that each contains a fundamental and many hundreds of both odd and even harmonics. Therefore, white noise is useful for tests.

Pink noise

"Pink noise" is similar to white

noise except the high frequencies are less prominent. Because the voltage decreases with frequency, pink noise sometimes is called 1/F noise.

Noisy components

Resistors, tubes, bipolar transistors, IC's, and FET's are the components in amplifiers that are most likely to cause noise. Certain kinds of leakage in capacitors or transformers and partial opens from corrosion in transformers can produce high noise levels. But we now are more concerned with devices that always have some amount of noise.

When current flows through them, all semiconductor materials have "thermal agitation noise" at room temperatures. It is molecular noise, and sometimes is called "Johnson noise".

At room temperatures, a 1-megohm resistor with current through it generates about 130 microvolts of noise.

In transistors, the base-spreading resistance (a fancy name for the resistance of the base/emitter junction) produces noise. A similar problem occurs in FET's. Thermal agitation is an example of white noise.

Another kind of noise created by amplifying components is called "partition noise". It is a form of pink noise, and is caused by a variation in the movement of charge carriers going to different electrodes. For example, electrons leaving the cathode of a tetrode tube might go to the plate, or they can go to the screen grid. From second to second, the number going to each electrode changes, even when no signal is applied. These variations cause partition noise, so pentodes and tetrodes generate more noise than triodes.

Partition noise occurs in bipolar transistors because the charge carriers can go either to the base or to the collector, and the exact number varies continuously.

Partition noise is not such a serious problem with FET's, but the whole channel is made of semiconductor material which produces thermal-agitation noise.

Shot noise

If you throw a handful of shot on a tin roof, the resulting sound will be a continuous noise caused by many separate individual shot landings. In the same way, electrons can be viewed as small particles leaving one electrode (cathode, emitter, or source) and arriving at another electrode (plate, collector, or drain). However, these charge carriers do not move at exactly the same speed. So, even if they leave at the same time, some will arrive at slightly-different times. This is "shot noise", an example of white noise.

Flicker noise

At any instant of time, the number of charge carriers leaving a cathode, emitter, or source will be different from the number at every other instant. This moment-by-moment variation produces "flicker noise". The intensity of the noise decreases with increasing frequencies, so it is a kind of pink noise. Flicker noise is common in vacuum tubes, and bothers some in transistors.

Next Month

Part 3 will discuss the types of distortion in amplifiers and speakers, and how to measure noise and distortion. □

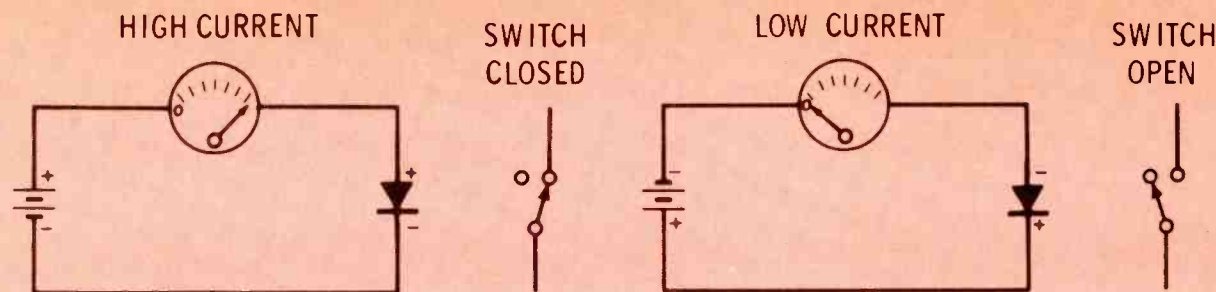
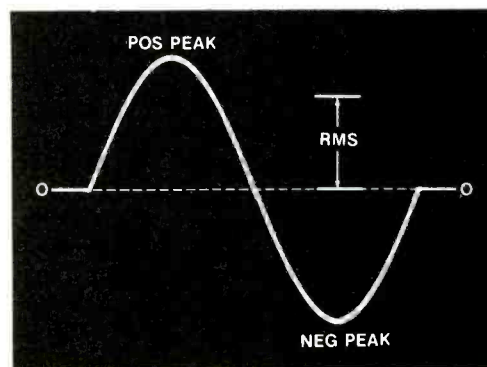

Fig. 1 When the anode of a silicon diode is about .6 volt (or more) positive relative to the cathode, the diode conducts heavily, becoming nearly a short circuit. When the anode is less than +.6 volt (or negative) relative to the cathode, a diode becomes an open circuit. Therefore, diodes are switches that are turned on or off automatically according to the polarity of the voltages applied to them.

(Almost) ALL ABOUT RECTIFICATION

Sweep-rectification circuits have focussed our attention on low-voltage power supplies, a subject that's usually ignored. The principles of rectification are important, not only for power supplies, but also for many other circuits. These include grid/cathode and base/emitter "diodes" when they are used as part of oscillators, AGC keyers, horizontal-output stages, sync separators, and many others. If you understand the basics of rectification, you'll know most of what's needed to work with these other circuits. BY Charles D. Simmons

Fig. 2 It's difficult to look at a sine wave and estimate the amount of work it can do. The slopes are so curved that a complex mathematical calculation must be used to determine the **effective** voltage. To make the visualization harder, half the waveform is positive and half is negative; therefore, over a period of time it appears that the voltage should average out to zero! Of course, this isn't true. We know AC can develop power and perform work because a resistor heats just as much on positive as it does on negative voltages. By definition, one sine-wave RMS volt equals one DC volt, when the load is a pure resistance. Further, the RMS voltage reading (the effective voltage over one **complete** cycle) equals 70.7% of the maximum **instantaneous** voltage of one peak of the sine wave. It's no wonder this illustration does little to clarify the relationship! The theory of rectification is much more clear without the stumbling block of RMS.



All rectifier circuits have some kind of diode as the heart. Diodes are available in many different forms, characteristics, and voltages. But one thing they have in common: they are one-way gates for current and voltage.

Figure 1 shows a simplified concept of solid-state diode action. A diode acts as an open circuit, ignoring any lesser forward bias, until the anode/cathode voltage exceeds +.6 or so volts. When sufficiently forward biased, a diode has a voltage drop of from .6 to 1 volt across it, depending on the amount of current flowing. In some circuits this voltage drop must be allowed for, but most rectifier circuits have so much voltage applied that the .6 volt is insignificant by comparison. Therefore, in the interests of simplicity, we'll forget about it, and about peak-inverse ratings, zener effects, and other precise ratings; thinking only of diodes as switches turned on or off by the polarity of the applied voltage.

Factors Determining DC Voltage

Read this list carefully, it might surprise you. The amount of DC output voltage obtained from any rectifier circuit depends on these factors (and **only** these):

- amplitude of the AC input voltage;
- waveform of the AC input voltage (often this is ignored because previously most power supplies operated from sine waves);
- the type of operation, such as peak-reading, RMS, choke input, half-wave, or full wave;
- the number of rectifier stages (single, doubler, tripler, etc.);
- capacitance of the **input** filter capacitor versus the ripple frequency and the amount of load;
- total resistance in series (current-limiting resistors, transformer windings, and even diode resistance); and
- total load on the DC output, including any capacitor or diode leakage.

Polarity Of Voltage

Here, repeated from last month's article on scan rectification, is a helpful definition that will answer many questions about DC polarity: **When a DC voltage is produced by diode rectification of an AC signal, the DC voltage is positive if it comes from the cathode; and it is negative if it comes from the anode of the diode.**

What Is RMS?

The letters RMS stand for Root-Mean-Square, a mathematical term meaning: AC voltage in RMS equals the square root of the sum of the squares of **all** instantaneous voltages, regardless of polarity. It is used most often to describe the amplitude of sine waveforms.

In Figure 2, the sine wave starts at zero voltage. Going up the positive peak, the first measurable volt-

age is squared, and that number is added to the next higher voltage squared, and so on up to the tip, then decreasing to zero. The negative tip is treated the same way. Each voltage is squared in turn, and all the squares are added together, followed by extraction of the root. That figure is the RMS value of the sine wave. Well, I certainly don't have patience enough to work such a problem! However, old-style square-law meters did it automatically, and modern meters do it by obtaining either an average or a peak-reading voltage that is **converted** to RMS by proper calibration of the analog dial scale. So much for the mathematical approach.

Sine-Wave Power

Now, let's attempt to clear some of the confusion created by illustrations of sine waves covered with

NEW FROM NIKOLTRONIX

made in U.S.A.

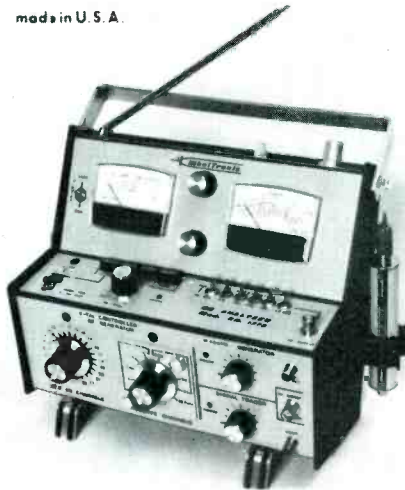

Crystal controlled **CB & COMMUNICATION ANALYZER MOD. GN-1375** with laboratory accuracy. **\$395.00** Inclusive rechargeable batteries. Less X-tals for reserve channels. Quality and dependability — at a price no one can ignore.....



2437 W. Peterson Ave.
Chicago, Ill. 60659
(312) 275-4727

Applications:

- For fast, professional servicing and checking on all makes of CB transceivers and other communications product.
- For testing unknown X-tals and X-tals accuracy from 3.5 MHz to 160 MHz.
- Alignment and calibration.
- Testing of mobile and base stations.
- Measurement of sensitivity (signal-to-noise ratio).
- Functions as modulated low pwr. transmitter or frequency references for system checkout.
- Measurement of true RF pwr. output to 50 W.
- Measurement of modulation percentage.
- Measurement of SWR (twd. & ref.).
- Monitoring relative field strength.
- Direct reading.
- 50 Ohms noninductive built in dummy load 50 W contin.

Features:

- RF generator has 23 X-tal controlled CB frequencies, as authorized by FCC • Each channel has individual crystal with tol. $\pm 0.002\%$ • 72 reserve channels from 3.5 MHz to 160 MHz. or Civil Air Patrol (C.A.P.), Radio control channels A, B, C, D and E, Special business band channels 22A, 22B, 24 and 25 **Optional**. • 455 kHz. IF signal • 400 Hz. audio signal • AC/battery operated for more flexibility • Two X-tal sockets are available for external X-tals • Calibrated RF output into 50 Ohms • Double RF shielding and aluminum cast RF attenuator with RF gasket • All critical circuitry are build in five (5) modules. They are made of chrome finish steel and sealed for dust and rain proof. **5 Years Guarantee on Modules** • Direct CW output min 5 V • Output connector for frequency counter for testing unknown X-tals and all RF. frequencies sources from GN-1375 • RF/AF Signal tracer with probe • Regulated power supply-charger with rechargeable batteries • RF wattmeter 0-10 and 0-50 W • Dummy Load 50 Ohms/50 W • SWR meter • RFS (relative field strength monitor) • % modulation.

For More Details Circle (8) on Reply Card

"peak," "peak-to-peak", "average", "RMS" and "DC" designations. How can a sine wave be equal to all those?

RMS versus the peaks

Refer again to Figure 2 for a moment. The textbooks tell us (correctly) that the RMS value of a sine wave is equal to .707 times the voltage of **one** peak. But how can a certain length of line equal a sine wave that has both positive and negative peaks? Also, the sine wave requires **time** to trace the entire waveshape, while the RMS line is given as an instantaneous value. That's mixing apples and bananas, for certain! The answer is that both a waveform and a mathematical quantity are being shown on one graph.

For the next step toward visualizing the RMS of a sine wave, we need to **invert** the negative peak, bringing it up alongside the positive peak (Figure 3). That doesn't

Fig. 3 Because both the positive peak and the negative peak furnish the same amount of power to a resistive load, we can make it easier to visualize the **average** voltage by inverting the negative peak, thus bringing it up level with the positive peak. Now, turn this page and look at the waveform from several angles, as you try to imagine where the point of average voltage might be. The tops are rounded and the bottoms are pointed, so there's probably more effective voltage at the top of the waveform. Therefore, the average-voltage line should be slightly above the 50% point. Mathematicians tell us the average voltage of this waveform is 63.7% and the RMS is 70.7% of one sine wave peak. That means RMS is

change the amount of work done, because a resistor heats the same on a negative voltage as it does on an equal positive one.

Both peaks now are on the same side of the zero line, so we can **look** at the waveform and make an educated guess about where the

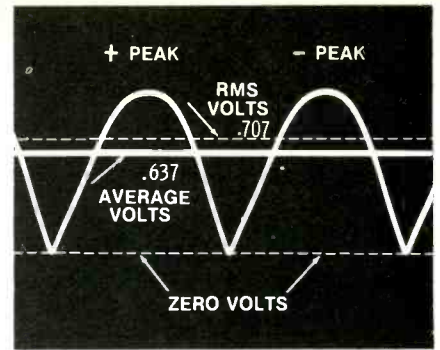

11% more than the average voltage, and the scope located the average-voltage line, so I merely measured up 11% higher on the photograph to locate the RMS line.

average voltage line might be. Better yet, we'll use the inherent ability of an AC-coupled scope to show the location of the **average-voltage** line. Then the RMS line is about 11% higher (multiply the average voltage by 1.11 to obtain RMS). If we have measured cor-

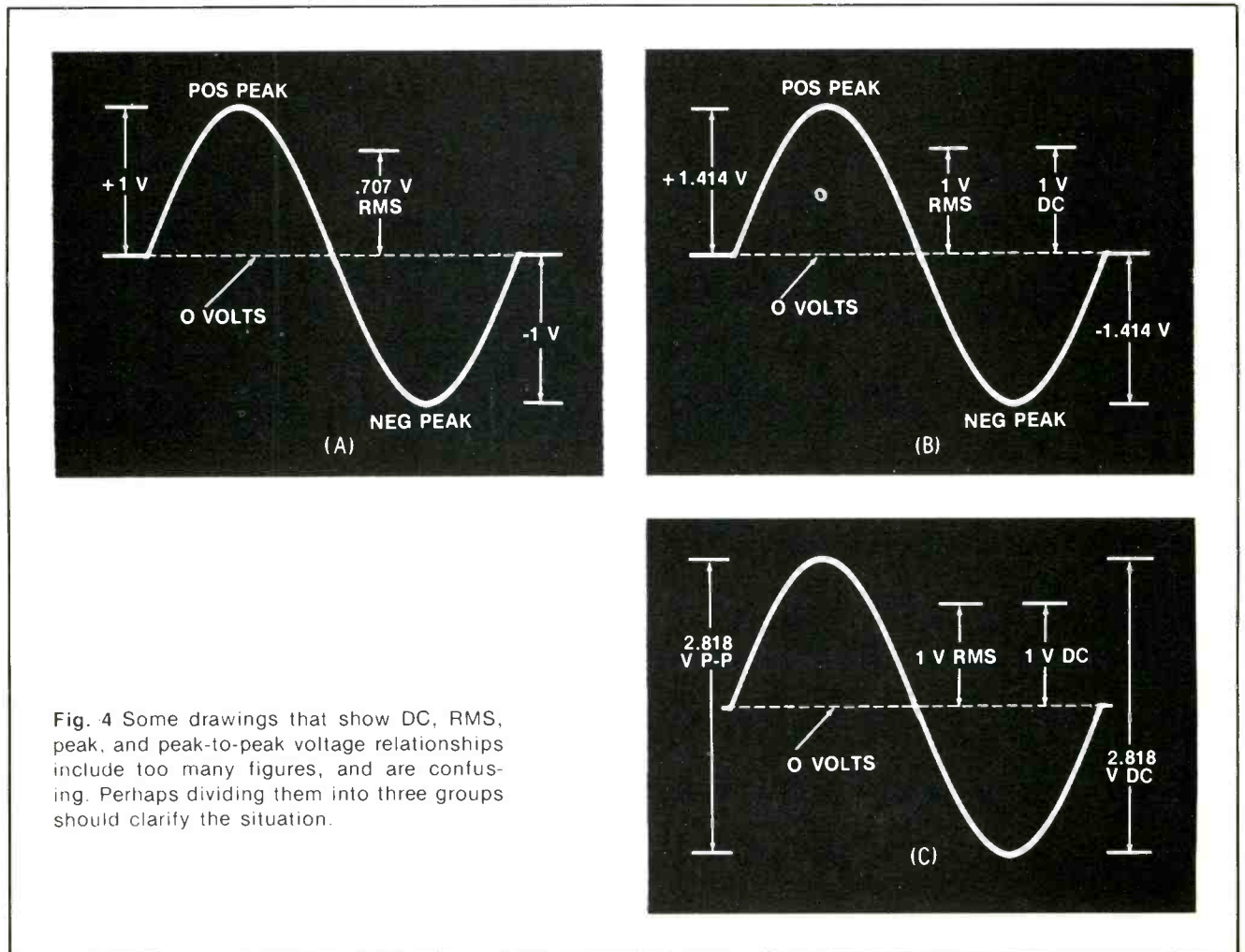

Fig. 4 Some drawings that show DC, RMS, peak, and peak-to-peak voltage relationships include too many figures, and are confusing. Perhaps dividing them into three groups should clarify the situation.

rectly, the RMS line should be about 70% up from the bottom. That's near enough for proof, and to help us visualize the situation.

RMS, peak, and peak-to-peak

Some textbook drawings attempt to show **all** the relationships between all ratings of AC waveforms by including them in just one illustration. To avoid this trap, we'll show them in three ways (Figure 4).

Voltage Versus Time

DC voltages either are there or not. Time is not a factor. But all AC voltages are time related. An AC waveform cannot be judged or measured until enough time has

passed for at least one complete cycle to be completed. That is, the exact instantaneous voltage depends on the phase (time of measurement during one cycle), and it must be measured from the **average-voltage line** (that's also the **zero-voltage line**, when **no DC is present**).

For years, I wrongly believed that the maximum AC voltage at **any one time** was measured from the positive peak to the negative peak. However, both peaks **never** are there at the same time. The total voltage between the two peaks is the peak-to-peak reading, which requires the time of one complete cycle. It is **not** an instantaneous voltage.

The zero-voltage line is vitally important, because at any one selected point in time there is only a certain amount of voltage relative to this zero-voltage line. And a rectifier can operate only on the voltage that's actually there. Therefore, a **single rectifier operates only on the instantaneous voltage from the zero-voltage point to the positive or negative voltage of the positive or negative peak**, according to which peak is used in that particular circuit. The other peak is ignored completely because it has the wrong polarity.

Half-Wave Rectifier

A simple half-wave power supply

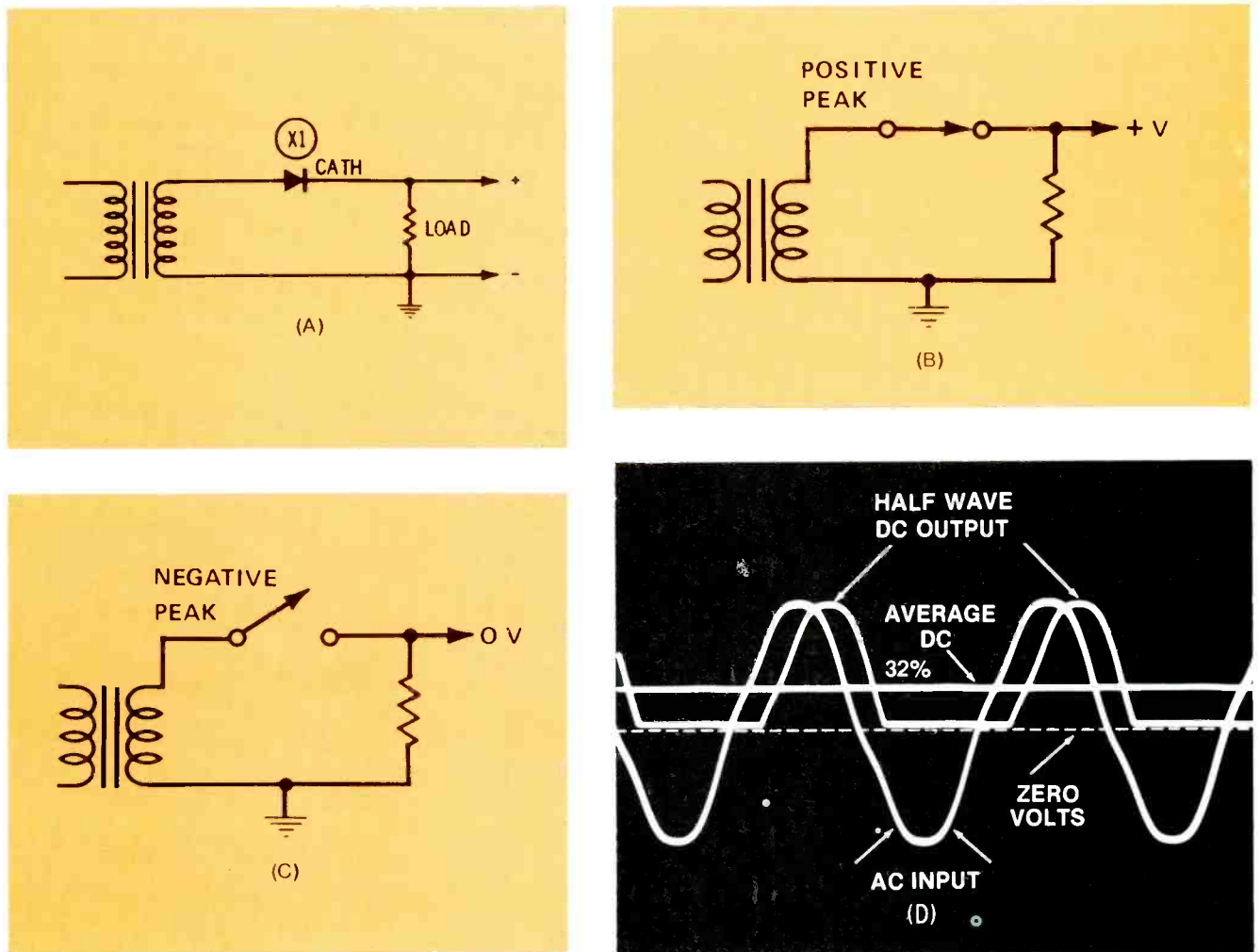

Fig. 5 The most-simple power supply has a source of AC voltage, a diode, and a resistive load (A). Using the analogy of a diode acting as a switch, these are the two conditions: during the positive peak, diode conduction connects the transformer winding directly to the load (B); and when the negative peak reaches the anode of the diode, the non-conducting diode prevents any voltage from reaching the load. (C). Therefore, the output should consist of positive peaks, with a zero-voltage line in between, as proven by the waveforms of (D). With normal dual-trace scope operation, the positive peaks and the peaks of DC in the output would overlap. So, to make the relationship more clear, the output trace was shifted slightly to the right. According to theory, the average voltage should be 32% of one input peak, and you can see that the average-voltage line (supplied by the scope) appears to be at about 1/3 height. The output signal is rated at 50% RMS, because the entire input sine wave is 100%, and the output is exactly half of the input signal.

without filtering is shown in Figure 5. The output consists only of the positive peaks of the input sine wave, and the peak voltage is the same as that of the sine wave positive peak. The positive peaks forced the diode to conduct (anode more positive than the cathode), while the negative peak stopped conduction.

During conduction times, the diode becomes nearly a dead short (less than 1 volt drop across it) connecting the input AC voltage at the anode to the output DC voltage at the cathode.

If the input AC voltage to the diode is rated at 100% RMS, the output here is 50% RMS. That's because the entire sine wave makes up the total RMS voltage; therefore, **either** peak would represent just half that amount.

Full-Wave Rectifier

Change the circuit of Figure 5 to a center-tapped transformer voltage source (providing an out-of-phase signal), add another diode to rectify the other peak, and the half-wave circuit becomes full-wave (Figure 6).

Think of it this way: the positive peak is rectified (passed through the diode X1) as explained before.

At that time X2 is reverse biased and acts as an open circuit without current. Time passes until the sine wave changes polarity with the negative peak at the anode of X1, which is reverse biased and without current. Now X2 has a positive anode voltage, so it conducts transferring the entire peak to the output load. Each diode conducts alternately as it receives a positive anode voltage.

Did you notice the resemblance between this **actual** output DC voltage waveform, and the one simulated in Figure 3 to help explain RMS and average voltages? Since they are the same, the output voltage has an AC RMS value equal to either input AC voltage. That is, the output RMS AC is 100% of the input (less only the drop across the diodes).

Peak-Reading Half-Wave Circuit

Figure 7 shows a half-wave rectifier that's similar to Figure 5 except for the addition of the filter capacitor, C1. Of course, the filter capacitor filters out most of the ripple. Everybody knows that! Unfortunately, the statement is a gross oversimplification.

Actually, the simple addition of the input capacitor makes it a whole new ball game! The previous two circuits had nothing to store or hold the DC voltage that was created by diode switching, making the average DC voltage equal to a certain small percentage of the input waveform.

For example, a half-wave circuit without an input capacitor would produce an **average** DC output voltage equal to 32% of one sine wave peak, or 16% of the peak-to-peak reading. The new circuit with an input capacitor has diode conduction **only** of the tip of the peak, and this voltage is stored in the capacitor between peaks. Theoretically, the output DC voltage should be equal to a peak of the input sine wave, a condition that's possible when the peak-reading circuit is lightly loaded. This is 100% of one peak, or 50% of the peak-to-peak reading. In other words, **the addition of an input capacitor can give up to a three-to-one increase of average DC voltage.**

If this seems to violate the laws of energy by giving something for nothing, don't get excited. The peak-reading circuit consumes more **wattage** from the source of AC.

Fig. 6 Addition of another diode and another winding of the power transformer changes the half-wave circuit into full wave (A). When the voltage at X1 is positive, it is negative to X2; therefore, X1 conducts and X2 is cutoff (B). As time passes, the voltages at the diodes change (C) so X2 conducts and X1 is cutoff. Each diode conducts alternately, as shown in (D). Because the output DC contains the equivalent of **both** peaks, it has a rating of 100% RMS. Theory and the average-voltage line indicate the effective output voltage is 63.7% of the instantaneous voltage of one peak (or in this case, of the maximum amplitude of the output waveform).

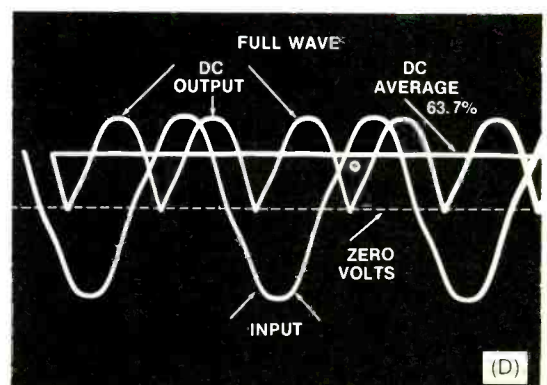
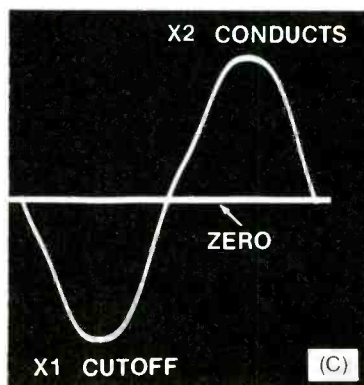
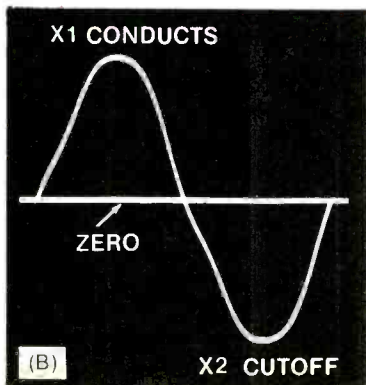
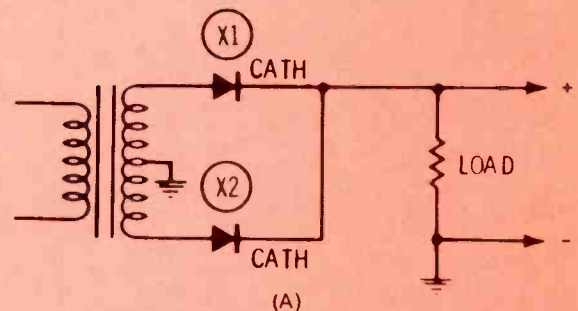

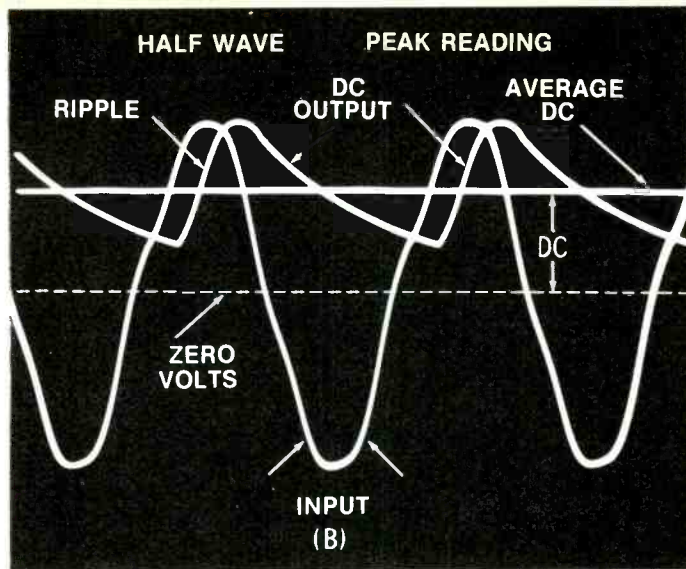
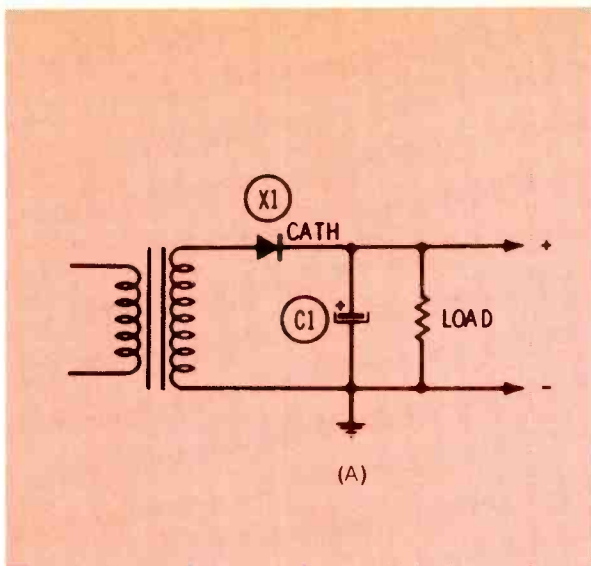

Fig. 7 A half-wave circuit with an added input filter capacitor (A), although similar to that of Figure 5, has a completely-different action. The filter capacitor stores DC voltage, partially filling in between the peaks, so the voltage never drops to zero. How far the voltage drops between the peaks of replenishing voltage depends on the filter capacitor and the amount of the load. If the load is light, the average DC voltage is nearly equal to the peak voltage of the input AC signal. In this case, the average DC was 57% of the positive-peak voltage. When the load was changed to a much-higher resistance, the voltage increased up to 95%. Here's how the circuit works: when the anode voltage becomes more positive than the cathode (connected to the filter capacitor), the diode conducts, connecting together the input AC and the output DC. The two voltages rise together until the input sine wave reaches the maximum positive point and starts to decrease. The cathode voltage is held for a time by the filter capacitor. When the anode voltage drops below the cathode voltage, the diode is cutoff, and the input and output no longer are connected. The anode voltage goes on its way, including the negative peak, but the diode remains cutoff. During this time, the capacitor discharges into the load, the waveshape following the classic curve. Before it reaches zero, the increasing voltage of the next positive peak makes the anode more positive than the decreasing DC voltage at the filter, so the diode conducts again, and continues to conduct until the sine wave starts down the positive peak. That's slightly more than one cycle.

And there is a huge difference in the waveform of the current in the two basic circuits. Current in the simple half-wave circuit has the same waveshape as the output waveform (that is, some current flows all the time the positive peak is at the anode.). However, the current of a peak-reading rectifier circuit has the shape of a narrow pulse that reaches maximum just before the tip of the input sine wave. The output ripple and the current waveforms of the two types of circuit are different.

This storage effect of the filter capacitor **does** reduce the ripple present at the output of the rectifier circuit. But it is not done by the action of a low-pass LC filter; it is not "filtering".

Waveforms of a peak-reading half-wave circuit when lightly-loaded and heavily-loaded are shown in Figure 7. With a heavy load, the highest point of the ripple has the same voltage from zero as the corresponding peak of the input sine wave, but more voltage is bled

from the capacitor before it is replenished by the next peak. That makes the average DC lower, and the ripple amplitude increased.

Peak-Reading Full-Wave Circuit

Add a filter capacitor to the circuit of Figure 6 to change it to peak-reading, as shown in Figure 8. Basically, the action is the same as that described for the half-wave peak-reading circuit, except the output ripple is 120 Hz because both diodes contribute, in turn, a replenishing pulse of voltage and current.

However, there are two other differences in the results. Addition of the input capacitor merely increased the average DC voltage by 157%, while the half-wave voltage was tripled. In other words, if you were measuring the DC voltage of Figure 8 and then disconnected the filter capacitor, the average DC voltage would decrease down to 63.7% of the previous voltage (or a decrease of 36.3%).

Also, the non-peak-reading ripple

was 50% of the input peak-to-peak, whereas the ripple dropped to about 1% (depending on load) when the capacitor was added.

Series rectification

The previous four circuits are called "series" types, because the diode is in series between the AC input and the output load. There is another basic type, used often in circuits other than power supplies, and found in conjunction with the series type in some doublers. It is called a "shunt" or parallel type.

Shunt Rectification

The other kind of rectifier circuit brings the AC input voltage in through the peak-reading capacitor, and has the diode in parallel with the load. Figure 9 compares series and shunt circuits.

Series rectifiers require an input AC source with a low resistance (the lower values give higher output voltages), and are not practical for most circuits where there is a mixture of AC and DC voltages.

Of course, the input peak-reading capacitance of the shunt type blocks any DC voltages that might be with the input AC. This feature makes the shunt type very desirable for rectifiers in VTVMs, because the DC component must be blocked to make accurate readings possible, and the high ripple is of no consequence, or can be filtered out easily.

Some resistance is necessary across the input (before C1 in Figure 9), but it can be a much higher value than with a series circuit. In most cases, such as when used in a VTVM, the resistance of the tube or transistor circuit being measured is sufficient.

With the series type of rectifier, it's easy to see how the capacitor stores the voltage and current, giving a smooth DC voltage nearly equal to the peak voltage. Shunt types are more difficult to visualize.

If fact, at first glance you would swear the diode would merely short out the input voltage! That would be true, were it not for the **timing** of the various steps. The explanation of how the circuit works is included with Figure 10; we will avoid duplication by not repeating it here.

Notice that conduction of the positive peak in a **series** circuit produces positive DC, and conduction of the negative peak (with reversed diode) produces a negative DC voltage.

The polarities for **shunt** circuits are just the opposite: conduction of a positive peak produces negative DC voltage, while conduction of a negative peak (by reversing the diode) produces a positive DC voltage.

In order for a shunt rectifier circuit to be peak-reading, the input capacitance must be large.

It's necessary that the input AC signal be passed to the diode without attenuation. In other words, 100% of the input amplitude must travel through the high-pass filter consisting of the input capacitor and the load on the output. Saying it a third way, this kind of rectifier has 100% ripple!

The 100% ripple is the reason the circuit is never used **alone** as a power supply; it would be extremely hard to filter out the ripple. However, the same high ripple is an advantage in other circuits, as we shall see later.

Shunt/Series Doubler

Figure 11 has a schematic that has been used in dozens of TV receivers to supply around +270 volts as the main power supply. It is a practical combination of a shunt peak-reading rectifier, that's followed by a series peak-reading type.

Fig. 8 Full-wave peak-reading power supplies (A) operate the same as the half-wave, except the phase-inversion of the power transformer changes the negative peak to a positive one, supplying twice as many replenishing pulses of DC voltage to the capacitor (120-Hz ripple). One effect is an increase of average DC voltage, because the capacitor has only half the time to discharge, and thus discharges only about half as much (B). When the load is light or the capacitor very large, the average DC output voltage is nearly equal to the voltage of either the positive and negative peak of input AC, as shown in (C). Another effect is that the ripple consists of small-amplitude sawteeth (inset). Straight sides of the ripple indicates the supply is operating near the maximum possible DC voltage from the peak-reading mode.

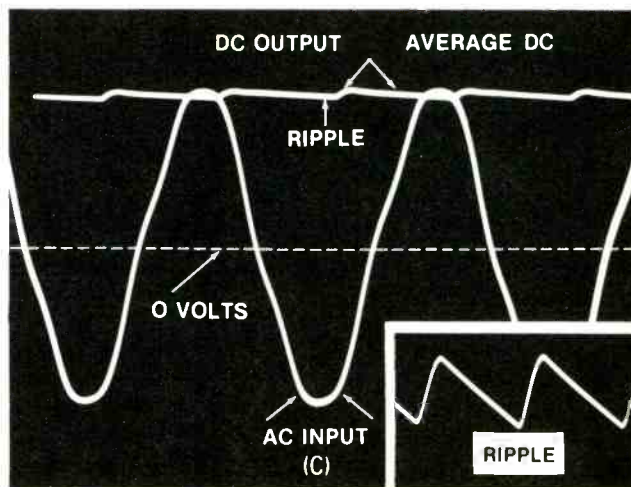
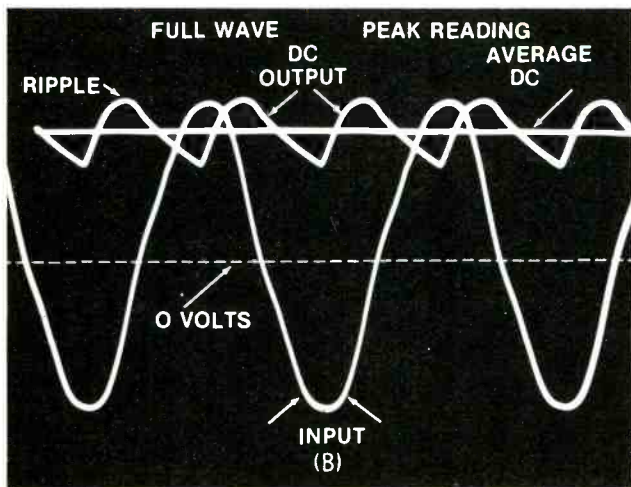
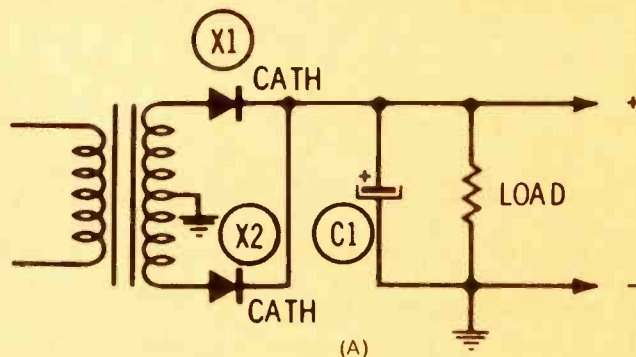

The shunt section produces about +130 volts DC, along with almost 120 volts of 60-Hz sine waves; and the series section passes the positive DC and rectifies the AC, producing nearly double the DC possible from either section alone. In effect, one voltage source is stacked on the other.

Because the last section is a series type, the output ripple has a low amplitude. However, there is one small drawback (other than the "hot chassis" connection) since the ripple is 60-Hz sawteeth. Although the diodes draw current on opposite peaks, the shunt section has an output ripple made up of 60-Hz sine waves, which are rectified and eliminated by the series section, leaving only 60-Hz sawteeth as ripple. The final ripple from the series section is the same as if it had been used without a preceding shunt section.

The combination shunt/series circuit is a DC voltage doubler, but not a frequency doubler. A similar circuit, with different values and polarities of diodes, is used as the rectifier section of some VTVM's. Because the circuit samples both peaks of the input waveform, it can be used to accurately read peak-to-peak voltages.

Hidden Shunt Rectifiers

Many shunt rectifiers are used in circuits other than power supplies. The grid/cathode elements of tubes can function as a diode; with the grid acting as an anode and the cathode functioning as a cathode. Also, the base/emitter junctions of transistors can function as anode and cathode in diode fashion.

Perhaps they are not often recognized as peak-reading shunt diode-rectifier circuits because the grid or base, in addition to operating as a kind of diode, also fulfills the normal function as an input element, producing an amplified signal at plate or collector. Figure 12 shows some examples of circuits, not usually associated with rectification, that do have grid/cathode or base/emitter rectification, in addition to other functions.

Analyze these circuits for yourself in the light of the facts about basic rectifications circuits, and see if you can explain why the grid of a horizontal output tube rectifies the **positive** tip of the oscillator drive

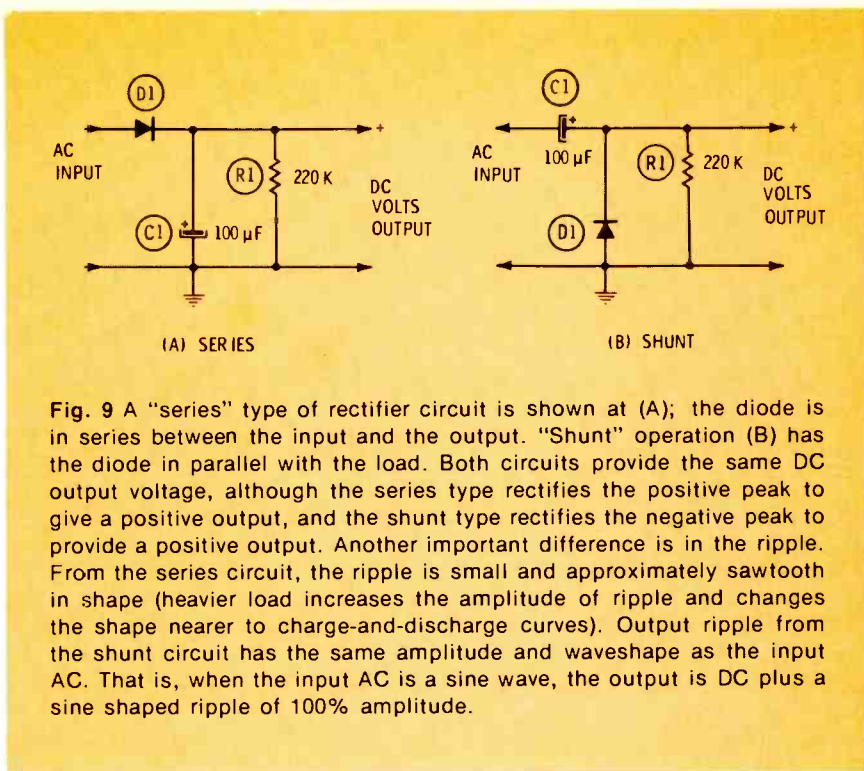

Fig. 9 A "series" type of rectifier circuit is shown at (A); the diode is in series between the input and the output. "Shunt" operation (B) has the diode in parallel with the load. Both circuits provide the same DC output voltage, although the series type rectifies the positive peak to give a positive output, and the shunt type rectifies the negative peak to provide a positive output. Another important difference is in the ripple. From the series circuit, the ripple is small and approximately sawtooth in shape (heavier load increases the amplitude of ripple and changes the shape nearer to charge-and-discharge curves). Output ripple from the shunt circuit has the same amplitude and waveshape as the input AC. That is, when the input AC is a sine wave, the output is DC plus a sine shaped ripple of 100% amplitude.

signal and produces a **negative** DC voltage at the output grid.

Rectification of Non-Sine Waveforms

Last month, I gave some information about sweep rectification of pulse and scan sections of the horizontal output signal. The following expands on that data, and adds the results of rectifying triangular, sawtooth (ramp), and pulses of different widths.

Where is the zero-voltage line?

We already have mentioned that any single rectifier circuit operates **only** on the voltage measured from the **zero-voltage point**. Every AC waveform develops gradually over a period of time; therefore, the only way to measure an instantaneous voltage on a waveform is relative to this mysterious point.

Seldom is this ever stated. Possibly because the zero-voltage line runs horizontally through the exact center of sine waves, separating them into equal positive and negative peaks. So either peak can be rectified, producing the identical DC voltage (except opposite in polarity, of course).

Some other waveforms **require** us to know the location of this zero line, because the peaks are **not** identical.

How can we **know** the location of the zero-voltage line? Well, it isn't necessary for you to believe some **drawing** in a textbook or magazine. **You can prove it with your own scope!**

Here's how to locate the line. First, the line actually shows **average** voltage, but if there is no DC present, it also is the point of zero voltage. So, use AC-coupling mode of the scope's vertical amplifier (thus eliminating any DC voltage). Lock in the waveform, and notice the location on the screen. Then remove the probe from the source of signal, and notice where the horizontal line is located, compared to the position of the waveform that just disappeared. That's all.

Sometimes it's difficult to flip back and forth from waveform to line fast enough to see it too well. There are two better ways. One is to photograph those two conditions using double exposure. The perfect way is to use a dual-trace scope. Using the vertical centering controls, AC coupling, and no signal input, adjust the horizontal trace of each channel so they overlap near the center of the graticule. Then add the desired waveform to channel one and lock it properly. Trace 1 shows the waveform, and trace 2 (without a signal) is the zero line for reference.

Fig. 10 Here's how a shunt-rectifier circuit (A) conducts during the positive peak, and yet produces negative DC voltage: When the positive peak appears at the input coupling capacitor, the diode conducts (B), grounding the output side of the capacitor. That causes the capacitor to accept a DC charge equal to the positive peak of the input AC voltage. At this time, the output voltage is approximately +.7 volt, which is the voltage drop across the diode, caused by the capacitor-charging current. The sine wave advances in phase, starting down the positive peak, and becoming less positive than the DC voltage stored in the capacitor. That stops the capacitor from charging, and the capacitor should begin to discharge rapidly in reverse through the low resistance of the winding and the diode, except that the loss of current causes the diode to become open, and the capacitor instead begins to discharge slowly through the winding and the load (C).

The output voltage is the sum of the AC voltage, from the winding, in series with the DC voltage stored in the capacitor. Measured from the winding of the transformer, the output of the capacitor is negative. So, at this time, the output is made up of positive voltage from AC in series with a slightly-higher negative voltage from the capacitor, making the output barely negative. For the remainder of the cycle, the capacitor loses only a small fraction of its voltage, while the AC voltage becomes progressively less positive, zero, negative, back to zero, and finally positive again. In other words, the negative DC capacitor voltage remains comparatively constant, but the AC goes through a sine waveform having both positive and negative voltages. The sum of these two voltage sources is in sine wave shape, however, it's all negative except for a tip that's barely positive (see the waveform in D).

When the tip of the positive peak arrives, it is slightly more positive than the capacitor voltage (because of a partial discharge through the load), and this makes the output voltage slightly positive, forcing the diode to conduct (grounding the output of the capacitor) and allowing the high-positive input voltage of the AC to replenish the charge of the capacitor. That's the first step of the second cycle of operation.

The average voltage is exactly in the horizontal center of the sine wave of output, so the average negative DC output voltage is equal to one peak of the sine wave of ripple (less any voltages lost in transformer winding and diode).

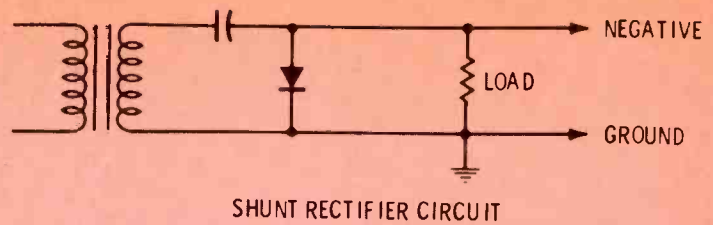

(A)

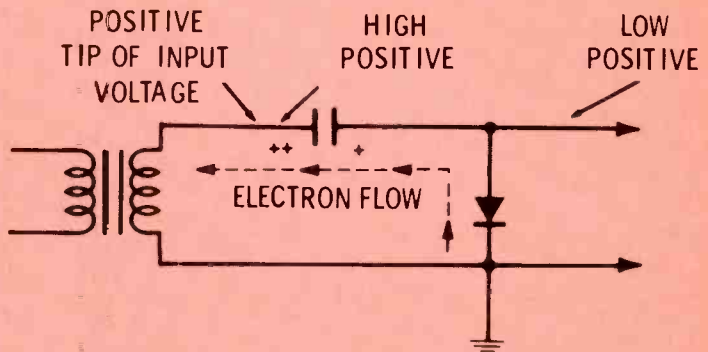

(B)

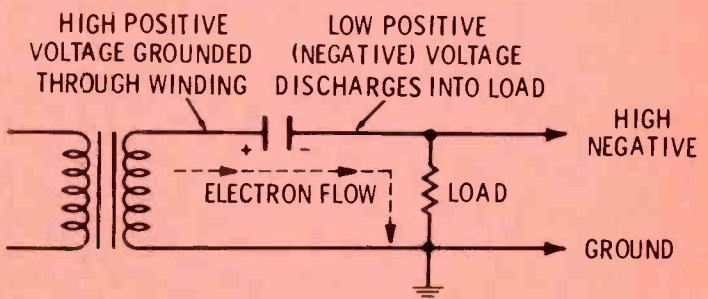

(C)

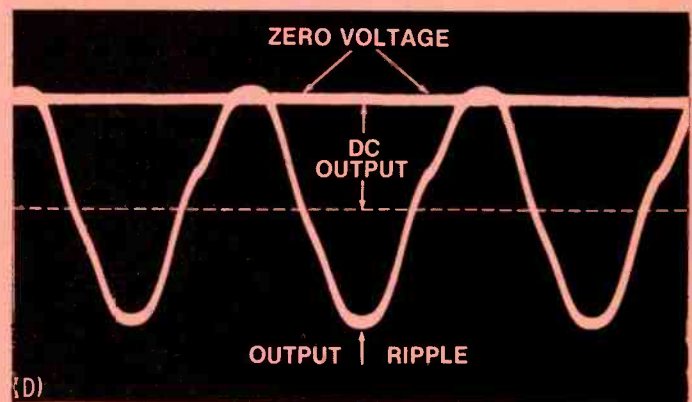

(D)

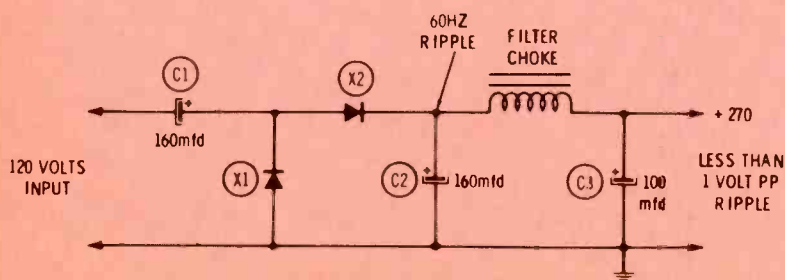

Fig. 11 The 100% ripple from a shunt rectifier becomes an asset, when the output of a shunt stage feeds a series rectifier. Both contribute DC voltage, so it is a voltage doubler. However, the ripple from the shunt stage is used as AC input by the series section. Therefore, the ripple from the series stage is conventional sawteeth of 60 Hz; the ripple frequency is not doubled.

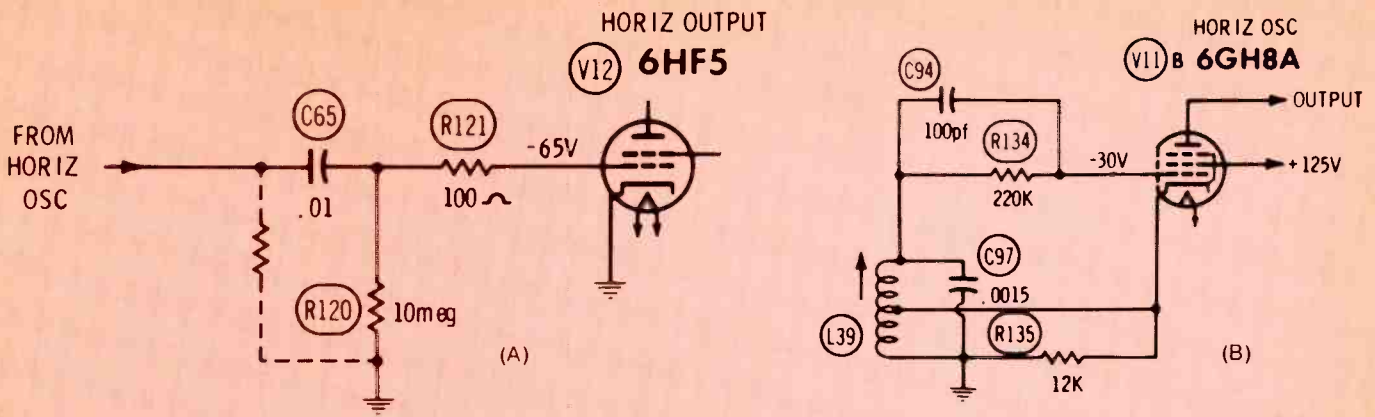
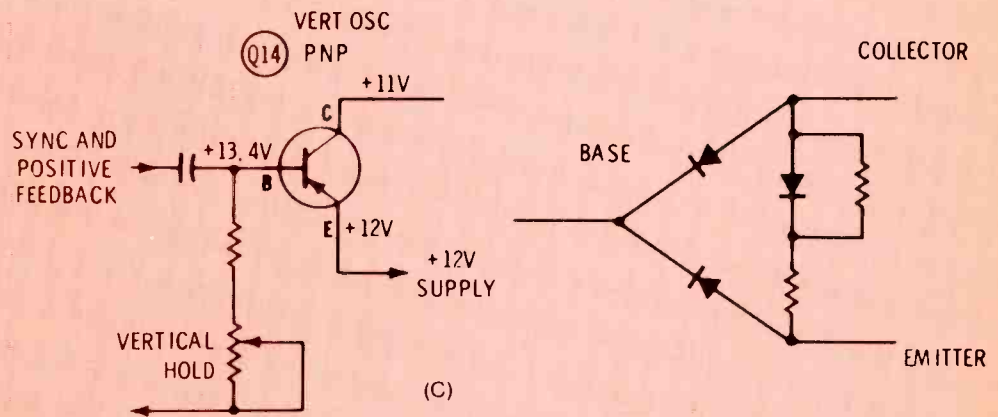

Fig. 12 Circuits (A) and (B) are two examples in which the grid functions as an anode of a diode, rectifying the incoming signal. Of course, the grid also acts as a control grid, producing gain by changing the plate current. The amount of DC voltage depends on the waveshape (how much voltage is in the positive peak) and the value of the capacitance versus the load. It is difficult to predict what DC voltage to expect, because conditions are not the same in each circuit.



The same facts apply to transistors (C), except an

NPN develops negative base voltage, while a PNP

generates positive base voltage by rectification.

Examples with zero lines

Figure 13 shows sine, triangle, square, sawtooth (ramp), and pulse waveforms with the zero-voltage line added by the dual-trace scope technique. Notice the symmetry of all waveforms (except the pulses), and the zero line running across the exact center. Some of the rise and fall lines were so rapid as to be invisible; therefore, they have been drawn on the actual waveforms to make them complete.

Rectify the positive peak of a symmetrical waveform and measure the DC voltage. Reverse the diode to rectify the negative peak, and again measure the DC voltage. The voltages will be exactly equal, but opposite in polarity. Not so with pulses, because the peaks are not similar, and the zero line does not run through the center. The amount of DC voltage obtained depends (with peak-reading) on which peak is rectified. The voltage ratio can be

as small as 3-to-1, or as large as 50-to-1 (narrow pulses). This is important with scan and pulse rectification in the new solid-state TV receivers.

With pulses, the position of the zero line depends on the exact waveshape, and especially on the width of the pulses, as shown in Figure 14.

What Is The Zero Line?

If the line of the waveform actually represents zero voltage, but there are positive and negative voltages on either side, then the part of the waveform above the line must equal in some way the part below the zero line. With symmetrical waveforms, that's easy enough to see at a glance. It's not that clear with pulses, because the differences are easier to notice. How, then, are the two peaks alike?

Here is the answer: the average voltage above the line exactly

equals the average voltage below the line. I decided to test that statement by rectifying the positive peak of a pulse waveform using a non-peak-reading circuit, then reversing the diode polarity and rectifying the negative peak. The positive and negative DC signals (see Figure 15) were measured by the DC-voltage function of a VTVM (which automatically gives an averaged reading) and found them to be nearly identical (except for the voltage drop across the diode).

In other words, the larger-amplitude voltage for a short period of time equals the smaller voltage that has a longer time duration.

Proof By Experiments

The figure .707 (the ratio of the RMS voltage to the maximum voltage of one peak of a sine wave) I accepted, because it seemed too difficult to prove. However, most of the other figures given by the text-

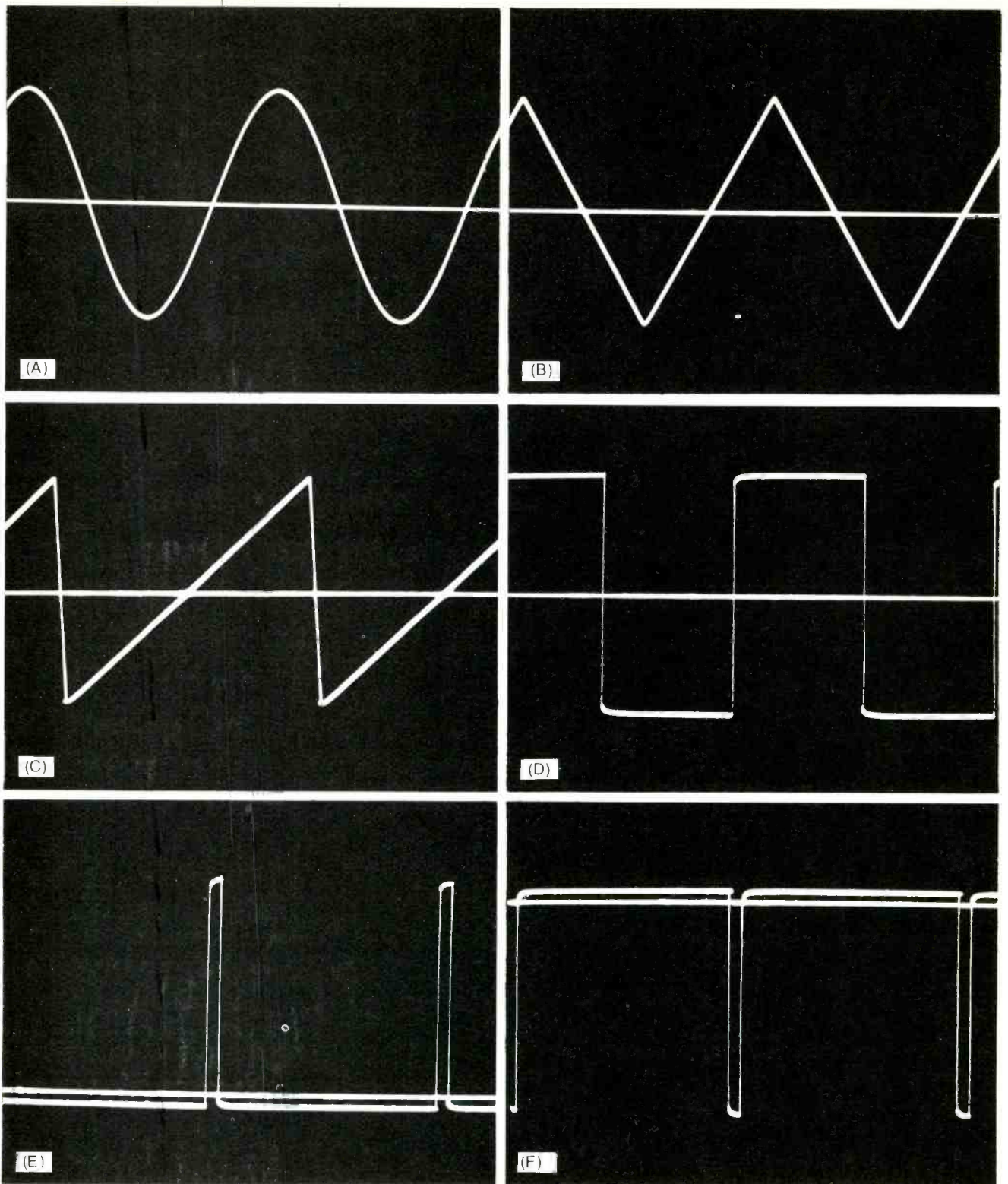

Fig. 13 The zero-voltage line goes through the exact center of sine waves (A), triangular waves (B), ramps (C), and square waves (D). However, the location of the zero line on pulses depends on the waveshape (E) and (F).

books were proved by measuring actual circuits. For example, measurements of the distances on an enlarged photo of a scope waveform indicated that the average voltage of a sine wave was approximately .9 of the RMS voltage.

Similarly, the factor of .32 for

changing peak-to-peak sine wave voltages to average, and the figure of .637 for converting the peak of a sine wave to average, were tested and found to be correct (within the limitations of the test equipment).

The photographs showing both the input AC and the output DC

waveforms together proved the assertion that every rectifier operates **only** on the voltage from the zero-voltage line to the peak that's being rectified.

Summary

Here are a few points and sug-

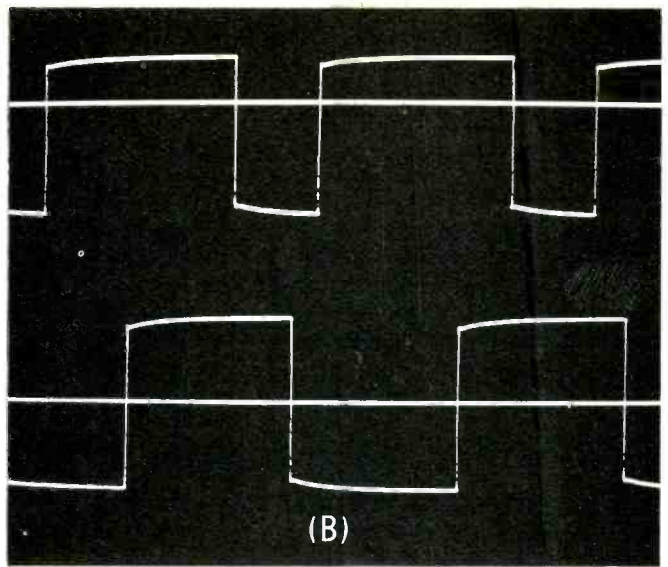
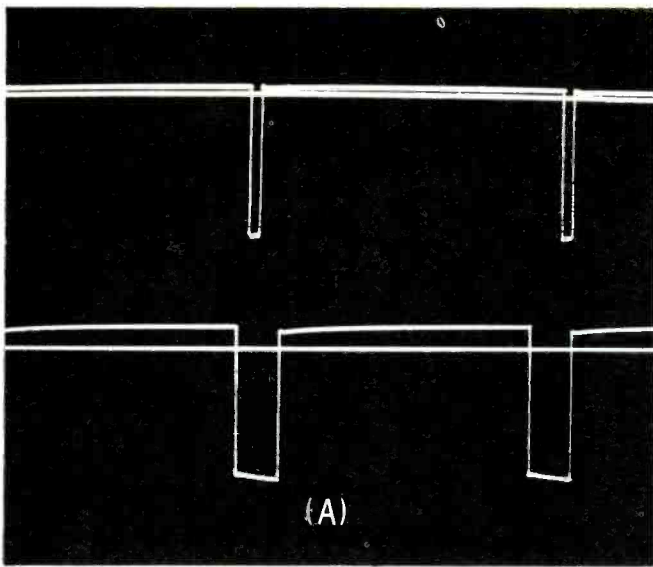

Fig. 14 Here are four widths of pulses (from a Hickok Model 270 function generator) with the zero-voltage line added by a scope. These are genuine waveforms; however, the vertical lines have been drawn in, otherwise they would have been invisible. It was interesting to see the zero line move, as the pulse widths were changed.

gestions:

- Forget about RMS when you think about rectifier circuits, it only confuses the analysis. Peak-reading rectification of a sine wave can produce as much as 1.414 times the

RMS rating of the input AC. How's that for perpetual motion? It's much easier to measure the peak-to-peak voltage of the AC input and take 50%. That's the maximum DC possible by peak rectification.

Of course, it's true that the same voltage of DC and RMS provides the same power to a resistive circuit. How many times do you need to measure that in a TV receiver?

- On a scope, DC, peak, and peak-

Need low-cost instruments for frequency counting? Period measurement? Events counting?



Here they are... the new Heathkit IM-4100

The new Heathkit IM-4100 is the most versatile low-cost counter we've ever offered. It's a full five-digit frequency counter that can also function in a period mode or as a totalizer. Built-in input attenuation and 12-volt operation add even more flexibility. As a frequency counter, it's guaranteed to 30 MHz with 1 Hz resolution. Sensitivity is a low 15 mV.

In the period mode, the IM-4100 measures intervals up to 99.999 seconds. Using the millisecond time base, it will resolve 1 msec!

The totalize mode will add up event pulses up to a count of 99,999.

The attenuator divides input signal amplitude by 1, 10 or 100. A pushbutton resets the display to zero in any mode. Front panel display includes overrange indicator and gate lamp. And the IM-4100 will operate from any 12-volt source through a rear panel connector.

We saved the best part for last. The complete price of the versatile, compact, easy-to-assemble Heathkit IM-4100 is only \$129.95*! For more information on this outstanding instrument value, send for your free copy of the latest Heathkit catalog.

Send for your free catalog.

HEATH Schlumberger	HEATH COMPANY Dept. 25-10 Benton Harbor, Michigan 49022
Please send my free Heathkit Catalog.	
NAME _____	
ADDRESS _____	
CITY _____	STATE _____ ZIP _____
*MAIL ORDER PRICES; F. O. B. FACTORY. PRICE & SPECIFICATIONS SUBJECT TO CHANGE WITHOUT NOTICE.	
TE-330	



For More Details Circle (9) on Reply Card

Fig. 15 An experiment was conducted to find out if rectifiers actually do operate only on the voltage from a selected peak, and also to determine if the effective values of the voltages of pulses on both sides of the zero-voltage line were equal. In (A) are shown the waveform of the input signal with zero line added by a scope (top trace), and the trace at the bottom is the output of a circuit similar to that of Figure 5, when the diode polarity was selected to pass the positive peak. Picture (B) shows the same things, except the diode was reversed to pass the negative peak. As you can see, only those portions of the waveform above or below the zero line came through. Also, a VTVM read the pulsating DC outputs as having almost identical DC voltages, one positive and one negative. This proved that the location of the zero-line contributed by the scope actually divided each waveform into two parts whose **average** DC voltages were opposite but equal.

Examine these waveforms, while you consider other conditions. Peak-reading rectification of the input signal of (A) would **not** increase the DC output voltage very much. Peak-reading capacitors fill in the spaces between the pulses of the output waveform, but in this case there's little space between. Therefore, little voltage increase is possible. By contrast, the output signal of (B) has large spaces between the pulses. Filling in the gaps by peak-reading action would greatly increase the DC output voltage.

For actual troubleshooting, one practical conclusion is that an open input filter capacitor in a scan-rectification circuit (conduction of the base line between pulses, not the pulses) would not appreciably decrease the DC voltage. On the other hand, an open input capacitor used for pulse rectification would decrease greatly the DC output voltage, perhaps by a 3-to-1 or 5-to-1 ratio. (The decrease would be much larger than with sine waves.) Also, the ripple would increase drastically, possibly causing strange symptoms as it entered other circuits.

Another conclusion is that the peak-reading DC output voltage from scan (not pulse) rectification is not decreased much by additional DC output current. But rectification of pulses develops much more ripple and suffers decreased average DC output voltage when the load on the supply becomes excessive. This is in addition

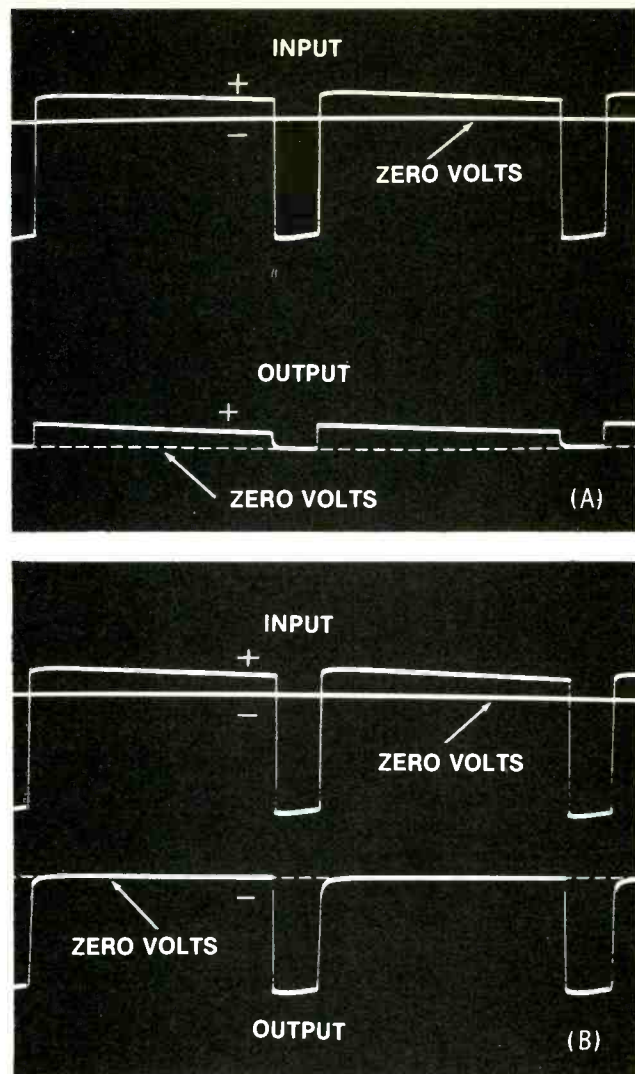

to any reduction of amplitude because of loading the horizontal-output stage, which is more susceptible to poor regulation during the pulse time.

to-peak calibrations are exactly the same. How can peak and P-P be the same? Peak-to-peak is the **total** amplitude from the maximum of one peak to the maximum of the other. Peak is the amplitude of any **portion** of the waveform. So, a scope can read either peak (portion) or P-P (total), while a meter can measure only the total waveform (peak-to-peak).

- Peak-reading rectifier circuits **don't necessarily** produce a DC voltage equal to the peak voltage of the AC input sine wave (or 1.414 times the RMS input). That's possible only with very light loads. Heavier loads cause more ripple, and ripple decreases the average (effective) DC voltage. For example,

measure the P-P reading of the ripple, and then divide it in half. That figure is the amount the DC output voltage is **below** the **maximum** peak-reading voltage.

- Many circuits are not intended to produce the **maximum** peak-reading DC voltage. That's why you can't measure the peak being rectified and obtain a DC output of the same voltage. (Examples: grids of vertical oscillators or blankers.)

- In a typical low-voltage power supply, **only** the first filter capacitor (the peak-reading one) decreases the DC voltage when it opens or is reduced in value. Other filters, following a filter choke, affect the amount of ripple, but not the DC voltage.

- With peak-reading circuits the **peak** rectifier current is much higher than it is with simple rectifiers. Peak-reading narrows the waveform of current; therefore, to obtain the same total power, the current during conduction must be larger. This must be considered when selecting replacement diodes. The peak current rating should be several times higher than the steady DC current drawn from the power supply.

Questions?

If you have a question about the theory or troubleshooting of rectifier circuits, please write to me in care of the editor. □

productreport

These features supplied by the manufacturers are listed at no-charge to them as a service to our readers. If you want factory bulletins, circle the corresponding number on the Reply Card and mail it to us.

Audio-Video Modulator

The **DYNAIR** Model TX-3A audio-video modulator adds closed circuit television programs into MATV, security, and IN-room movie systems. This \$495.00 solid-state unit provides a crystal-controlled combined aural and visual output on any single VHF channel, and is said to be ideal for adding a TV camera or VCR signal to multi-channel distribution systems.

The TX-3A requires only to be level matched into the system; no additional filters or traps for this unit are necessary. Independent metering is provided for percentage of modulation, and the RF output is front-panel adjustable over a 10-dB range.

For More Details Circle (50) on Reply Card

Cordless Soldering Iron

Weller's portable self-contained soldering iron provides 700°F heat within 6 seconds, for about 15 minutes of soldering. The unit is contoured and balanced for hand comfort, and features three interchangeable tips, built-in work light, and safety-lock switch.

Rechargeable nickel cadmium batteries and overnight power charger are included with the WC100.

For More Details Circle (51) on Reply Card

Foreign TV Semiconductor Kit

Developed by **General Electric**, a kit of semiconductors crossing over 25,000 JEDEC numbers covers devices needed for the repair of consumer electronics equipment made by Sony, Hitachi, Panasonic, Toshiba, and other Far East firms.

Kit K934 comes in a 24-drawer parts cabinet with a carrying handle.

For More Details Circle (52) on Reply Card

Parts and Equipment Manual

Wire, cable, solid-state devices, test equipment, timers, connectors, relays, tools, and capacitors are only a few of the electronic parts and equipment described in the 1976 **Engineering Manual & Purchasing Guide** from **Allied Electronics**.

Complete specifications and illustrations describe a wide variety of new products as well as traditional items from Allied and other leading manu-

facturers.

The guide, a \$5.00 value, now is available for \$1.00.

For More Details Circle (53) on Reply Card

Video-IF Transistors

Solid State Systems offers a new line of transistors for video-IF/AGC stages, providing universal replacements in critical circuits at low, medium, and high-range beta.

PR-284 is designed for low-range response; PR-343 for medium-range; and PR-344 for high-range response.

For More Details Circle (54) on Reply Card

Staple Gun Tacker

T-37 from **Arrow Fastener Company** safely and rapidly secures wires up to 5/16-inch in diameter using staples with rounded crowns for a snug fit. The tapered striking edge permits working in close corners, a grooved guide positions the wires, and a grooved driving blade stops the staple at the right height to minimize damage to the wires.

Constructed of steel with chrome finish, Model T-37 staple gun takes 3/8", 1/2" or 9/16" staples.

For More Details Circle (55) on Reply Card

A hand-y gift from Perma Power...

WHEN YOU BUY THIS MONEY-SAVING FOUR-PACK OF PERMA POWER COLOR-BRITES.



Now you can save \$4.65 on the briteners you use most—Perma Power Model C-511 Color-Brite—and get a pair of Royaltan 600 work gloves absolutely free! You'll find these gloves handy for antenna installations, lifting TV sets, driving, or general work inside and out.

You'll find the C-511 Color-Brite handy, too. No complicated installation, just plug it in; and instantly restore sharpness, contrast and faded color to color television picture tubes. Perma Power Color-Brite extends useful picture tube life up to a full year, makes your customer happy so she'll remember you when it's time for picture tube replacement.

The Perma Power Model C-511 fits all the prevalent rectangular picture tubes with 60 Hz heaters. For a limited time, you can buy well below the usual price of \$6.15 each, with this four-pack for just \$19.95—a \$4.65 total savings. And the gloves are free! Hurry, supplies are limited. See your distributor today.

Perma Power®

Chamberlain Manufacturing Corporation
Perma Power Division
5740 North Tripp Avenue, Chicago, Illinois 60646
Telephone (312) 539-7171

For More Details Circle (72) on Reply Card

Checklist of Books for Electronic Technicians!

- Practical CB Radio T shooting & Repair 210 p., 108 il. \$5 95
- Adv. Applications for Pocket Calculators 304 p., 275 il. \$5 95
- Handbook of Multichannel Recording 322 p., 196 il. \$7 95
- Small-Screen TV Servicing Manual 240 p., 367 il. \$6 95
- Integrated Circuits Guidebook 196 p., 124 il. \$5 95
- Computer Programming Handbook 518 p. \$8 95
- Transistor Theory for Technicians & Engineers 224 p. \$5 95
- TV T shooter's Handbook—3rd Ed. 448 p., over 300 il. \$4 95
- Tower's International Transistor Selector 140 p. \$4 95
- CATV Circuit Engineering 294 p., 138 il. \$14 95
- Jack Darr's Service Clinic No. 3 252 p., 124 il. \$4 95
- Color TV Studio Design & Operation 168 p., 69 il. \$9 95
- Auto Electronics Simplified 256 p., 202 il. \$5 95
- Color TV Case Histories Illustrated 238 p., 219 il. \$5 95
- The Home Appliance Clinic 195 p., 61 il. \$4 95
- The Complete FM-2Way Radio Handbook 294 p., 111 il. \$6 95
- Directional Broadcast Antennas 210 p., 60 il. \$12 95
- Practical Guide to MATV/CCTV Sys. Design/Serv. 252 p. \$5 95
- Effective T shooting With EVM & Scope 238 p., 185 il. \$5 95
- RF & Digital Test Equipment You Can Build 252 p., 217 il. \$5 95
- Basic Digital Electronics 210 p., 117 il. \$4 95
- Elec. Test Equipment—& How To Use It 204 p., 174 il. \$4 95
- Color TV Trouble Factbook—2nd Edition 348 p. \$4 95
- Servicing Cassette/Cartridge Tape Players 294 p., 196 il. \$6 95
- Small Appliance Repair Guide—Vol. 2 210 p., 119 il. \$4 95
- Indexed Guide To Modern Electronic Circuits 216 p., 92 il. \$4 95
- Electronic Measurements Simplified 240 p., 217 il. \$4 95
- CET License Handbook 276 p., 244 il. \$5 95
- Solid-State Circuits Guidebook 252 p., 227 il. \$5 95
- 10-Minute Test Techniques For PC Serv. 216 p., 114 il. \$4 95
- Auto Stereo Service & Installation 252 p., 245 il. \$5 95
- Logical Color TV Troubleshooting 240 p., 151 il. \$5 95
- Cassette Tape Recorders—How They Work—Care/Repair \$4 95
- Pictorial Guide to CB Radio Installation & Repair 256 p. \$5 95
- TV Bench Servicing Techniques 228 p., 177 \$4 95
- Questions/Answers About Tape Recording 264 p., 102 il. \$5 95
- How To T shoot & Repair Electronic Test Equip. 252 p. \$6 95
- Modern Communications Switching Sys. 276 p., 171 il. \$17 95
- Understanding & Using the VOM & EVM 192 p., 187 \$4 95
- Electrical Wiring/Lighting For Home/Office 204 p., 155 il. \$4 95
- Practical Test Instruments You Can Build 204 p., 157 il. \$4 95
- Mobile Radio Handbook 192 p., 175 il. \$4 95
- Understanding & Using the Oscilloscope 272 p., 170 il. \$4 95
- FM Stereo/Quad Receiver Servicing Manual 192 p., 130 il. \$4 95
- 125 Typical Elec. Cir. Analyzed/Repaired 208 p., 160 il. \$4 95
- MATV Systems Handbook 176 p., 91 il. \$4 95
- T shooting Solid-State Wave Generating/Shaping Circ. \$4 95
- 2nd Class FCC Encyclopedia 602 p., 445 il. \$7 95
- Acoustic Techniques for Home & Studio 224 p., 168 il. \$5 95
- Pictorial Guide to Color TV Circuit Troubles 256 p., 262 il. \$4 95
- Marine Electronics Handbook 192 p., 106 il. \$4 95
- Installing TV & FM Antennas 168 p., 158 il. \$3 95
- Basic Audio Systems 240 p., 203 il. \$4 95
- Simplified TV Trouble Diagnosis 320 p., 292 il. \$5 95
- Pictorial Guide to Tape Recorder Repairs 256 p., 320 il. \$4 95
- Introduction to Medical Electronics 272 p., 126 il. \$6 95
- Troubleshooting Solid-State Amplifiers 256 p., 95 il. \$4 95
- How to Solve Solid-State Circuit Troubles 304 p., 161 il. \$5 95
- T shooting Solid-State Elec. Power Supplies 192 p., 85 il. \$4 95
- How to Interpret TV Waveforms 256 p., 250 il. \$4 95
- Kwik-Fix TV Service Manual 384 p. \$5 95
- How to Repair Musical Instrument Amplifiers 288 p., 250 il. \$5 95
- Solid-State Circuit T shooting Guide 224 p., over 150 il. \$4 95
- Installing/Serv. Elec. Protective Systems 252 p., over 160 il. \$4 95
- Using Elec. Testers for Automotive Tune-Up 252 p., 226 il. \$4 95
- All-in-One TV Alignment Handbook 304 p., 145 il. \$5 95
- 199 Color TV Troubleshoot Solutions 224 p., over 180 il. \$4 95
- 199 Electronic Test & Alignment Tech 224 p., 130 il. \$4 95
- Digital Electronics: Principles & Practice 288 p., 191 il. \$5 95
- Industrial Electronics: Principles & Practice 416 p., 380 il. \$8 95
- Commercial FCC License Handbook 444 p., 150 il. \$5 95
- Citizens Band Radio Service Manual 192 p., 36 il. \$5 95
- Modern Radio Repair Techniques 260 p., 36 il. \$4 95
- How to Use Color TV Test Instruments 256 p., 230 il. \$4 95
- Modern Radar—Theory, Operation, & Maint 480 p. \$7 95
- Popular Tube-Transistor Substitution Guide 256 p. \$3 95
- 199 TV Tough-Dog Problems Solved 252 p., 199 il. \$5 95
- Major Appliance Repair Guide 288 p., illus. \$5 95
- Computer Technician's Handbook 480 p., over 400 il. \$8 95
- Vectorscopes-Oscilloscopes & Sweep-Marker Gen. 256 p. \$4 95
- Practical Electronic Servicing Techniques 256 p. \$4 95
- TV Trouble Diagnosis Made Easy 256 p. \$5 95
- Servicing Modern Hi-Fi Stereo Systems 248 p., 24 il. \$4 95
- Pulse & Switching Circuits 256 p., 184 il. \$5 95
- How to Repair Home/Auto Air Conditioners 208 p. \$4 95
- Home-Call TV Repair Guide 144 p. \$3 95
- Small Appliance Repair Guide—Vol. 1 224 p., over 100 il. \$4 95
- 101 TV Troubles From Symp. to Rep 224 p., over 170 il. \$4 95
- Installing/Serv. Home Audio Systems 256 p., over 150 il. \$5 95

NO RISK COUPON—MAIL ENTIRE AD

TAB BOOKS, Blue Ridge Summit, Pa. 17214

Please send me the books checked above.

- I enclose \$_____ send postpaid
 Please invoice on 10-day FREE trial Send C.O.D.

Name _____ Phone _____

Company _____

Address _____

City _____ State _____ Zip _____

Foreign add 10% Pa. add 6% sales tax ES-105

For More Details Circle (10) on Reply Card

Weather Alarm Radio

Model ACT-A 4W radio provides automatic weather information from the National Weather Service, and 3 channels to monitor the activities of emergency crews on VHF High Band



in the event of disaster.

A switch takes the radio off alarm status, putting it on a patented programmable scan. The \$125.00 monitoradio/scanner from Regency Electronics includes a built-in speaker and detachable telescope antenna.

For More Details Circle (56) on Reply Card

IC Test Clip

Model 4124 IC test clip is designed for attachment of test probes to 24-pin lead dips. Dip Clip's® positive positioning reportedly helps prevent accidental shorting while testing live circuits.

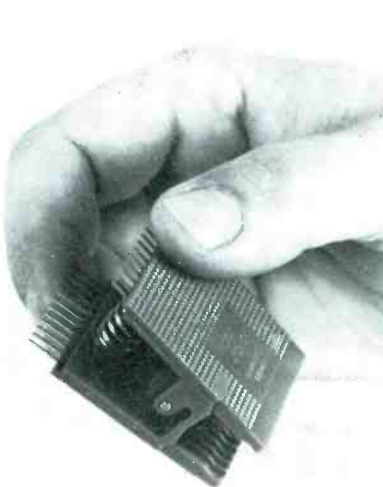

Other features of this product from ITT Pomona Electronics include nickel-silver friction-grip contacts, and spring-loaded wiping action of the contact pins, which reportedly gives good electrical connection.

For More Details Circle (57) on Reply Card

Replacement Semiconductor Guide

A 178-page guide from General Electric features over 73,000 cross references to 250 GE universal replacement semiconductors, including application and technical data on the de-

VICES and outline drawings with dimensions.

Included in the 1975 edition are over 40 new entertainment semiconductor devices in the GE line for TV, FM, and FM stereo applications. Also covered in the \$1.00 guide are 15 accessories, such as transistor heat sinks, transistor sockets and integrated-circuit sockets, and details on 20 experimenter/hobbyist components.

Suggested user prices on all devices are listed.

For More Details Circle (58) on Reply Card

Tubeless TV Camera

Two solid-state tubeless black-and-white TV cameras from RCA employ an advanced type of image sensor, called a charge-coupled device (CCD),

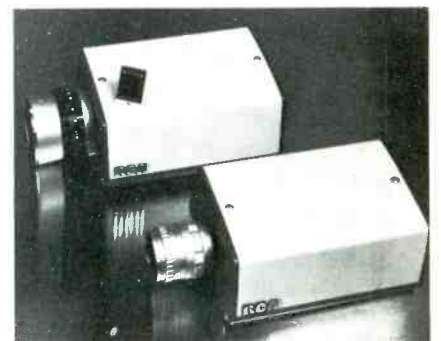

which performs the functions of vidicon tubes. The sensor is a 512 X 320 element device capable of producing fully standard 525-line video for use in either color or black-and-white TV cameras.

According to RCA, the CCD is the first sensor to be compatible with standard TV monitors and accessories, eliminating the need for equipment modification.

Model TC1150 TV camera has a built-in lens which is part of a unique automatic light control system that can quickly adapt over a wide range of scene illumination.

The TC1155 model accepts standard "C" mount interchangeable lenses for greater flexibility.

For More Details Circle (59) on Reply Card

Telephone Privacy Button

When talking on the telephone, it's often necessary to speak to someone else without the caller hearing what is said. Goodrich Products introduces Sound Barrier, a "hold" button that attaches to your telephone in seconds.

By pressing the button and temporarily cutting off the transmitter, you can have another conversation without interrupting the party on the line.

The price of the Sound Barrier is \$4.95.

For More Details Circle (60) on Reply Card

test equipment report

These features supplied by the manufacturers are listed at no-charge to them as a service to our readers. If you want factory bulletins, circle the corresponding number on the Reply Card and mail it to us.

Compatible Color TV Test Jig

Equipped with a 1906P22 kinescope, the compatible color TV test jig from RCA has specially-designed built-in transformers and a switching system for testing almost all American TV receivers. Yoke impedances are matched by turning two switches; there are no additional transformers to buy or plug in.



Model 10J106 works with tube-type, hybrid, and solid-state chassis, and is supplied with cables to fit all RCA color console chassis manufactured within the past 10 years.

Featuring a built-in high voltage meter calibrated to 35 KV complete with high voltage lead, ground lead, kinescope and yoke cables, plus audio-cable and speaker, the unit is dealer-priced at \$339.95 each.

For More Details Circle (61) on Reply Card

Maintenance Meter Kit

Triplett Corporation's drop-proof and burnout-proof Model 60 VOM also is available in an electrical-mainten-



ance kit. The 28-range general-purpose test instrument is packaged in a sturdy case, which protects the unit

against accidental drops up to 5 feet, and features a non-slip finger tread finish for handling ease. Model 60 is diode and fuse-protected up to 1000 volts, and was designed within strict safety standards to prevent explosive arcs in circuits up to 1000 volts. Completely insulated, the unit comes with 48-inch long safety leads and a single selector switch.

The \$150.00 kit comes complete with Model 60 VOM, Model 10 clamp-on AC ammeter, Model 10 attachment lead, Model 101 line separator, leather storage case, safety test leads, insulated alligator clips, batteries, spare 1/8 ampere and 1 ampere fuses, and an instruction manual.

For More Details Circle (62) on Reply Card

Self-Contained Current Measuring Probe

Eico Electronic Instrument Company has introduced a self-contained, direct-reading, high-voltage and current-measuring probe for safe measurements of voltages up to 40,000 volts DC and separate DC current measurements up to 200 milliamperes.

Model HVP-5 has two separate circuits; only the meter is switched. The unit reportedly cannot be damaged by placing the function switch in the current position while measuring high voltage. This feature allows the technician to switch from current measurements to the HV test without turning off the set being tested.



HVP-5 is available factory-wired for \$29.95.

For More Details Circle (63) on Reply Card

Frequency Counter

High accuracy, ruggedness, and reasonable cost are features of the Model 5383A Hewlett-Packard 9-digit frequency counter. To protect the input circuitry against damage from transients or excessive input levels, the 50-ohm input is fused. An input switch selects 50-ohm, or 1-megohm with either X1 or X10 attenuation. Gate times can be set for .1, 1.0 or 10 seconds.

For More Details Circle (64) on Reply Card

pliers
pliers
pliers



BY Xcelite®

ALL THE TYPES
YOU NEED IN A
FULL RANGE OF SIZES

From 4" miniature electronics to 10" utility. Precision made in U.S.A. Forged alloy steel construction. Cleanly milled, perfectly aligned jaws. Hand-honed, mated cutting edges. Most with Cushion Grip handles.



INCLUDING

5" Bent Thin Chain Nose. For handling fine wires in close quarters. No. 79CG

5 1/2" Thin Needle Nose. For firm gripping and looping of wires. No. 57CG

4" Full Flush Cutting Diagonals. Snap cuts to the extreme tip. No. 84CG

5" Midget Slip Joint. Narrow jaws for close quarters. 3 openings to 1/2". No. 50CG

Ask your local distributor or write...

**Weller-Xcelite
Electronics Division**



The Cooper Group

P. O. BOX 728,
APEX, NORTH CAROLINA 27502

For More Details Circle (11) on Reply Card

audio systems report

These features supplied by the manufacturers are listed at no-charge to them as a service to our readers. If you want factory bulletins, circle the corresponding number on the Reply Card and mail it to us.

Noise-Cancelling Microphone

For use in noisy environments such as airports, garages, factories, and restaurants, Model 562 microphone features a smooth frequency response of 100 to 6,000 Hz for clear voice transmission, while its noise-cancelling capabilities help minimize interference from background noise.

Model 562 is a low-impedance microphone, and can be used with long lengths of cable reportedly with no effect on response or output level.

With its attached cable and standard 5/8-inch 27 thread, the \$55.00 unit from **Shure Brothers** can be installed in a gooseneck or general desk stand for paging and base-station applications.

For More Details Circle (65) on Reply Card

Half-Octave Equalizers

The SAE half-octave equalizers offer a "pink-noise" generator, and harmonic and intermodulation distortion reportedly of less than 0.02

percent.

The 27B equalizer is for home use and is priced at \$550.00. A rack-mounted version for professional application, Model 2700B, sells for \$600.00.

Professional slide controls give the user up to ± 16 dB range at any or all of the 20 frequency bands. The pink-noise generator provides wide-band noise for use in determining proper channel balance, room response, and speaker phasing.



Both units come with a free five-year service contract on parts and labor.

For More Details Circle (66) on Reply Card

Automatic Limiting Amplifiers

The ALA series from **Bell P/A Products** is designed for telephone or intercom paging applications where a number of paging sources cause wide variations in volume.

Available in 4 models with power outputs of 20, 45, 90, and 200 watts, the amplifiers feature up to 30-dB of level limiting.

The units are designed for 24-hour duty, and are available in a 19-inch rack mount.

For More Details Circle (67) on Reply Card

Auto Stereo Speaker

Quam-Nichols has made available an air-suspension speaker for auto stereo and other hi-fi applications. The 6" X 9" oval speaker features an

independent 3-inch tweeter. Voice coil impedance is 8 ohms.

Each speaker lists for \$24.75.

For More Details Circle (68) on Reply Card

Headphone Adapter

An adapter for connecting stereo headphones to cassette recorders, players, radios, TV, or other monaural program sources has been developed by **Switchcraft, Inc.**

To use, simply plug in the headphone to the extension jack on one end of the adapter, and plug in the other end to the phone jack on the mono source.

Model 396P1 features a molded-on miniature commercial phone plug which is shielded and has a built-in strain relief.

Model 396P1 is priced at \$4.15.

For More Details Circle (69) on Reply Card

Trunk-Mounted Speaker Enclosure

A trunk-mounted speaker enclosure for 6X9 speakers, the **Kar Kriket™** 60-UD features two flexible straps and clamps for quick, easy installation.

From **Acoustic Fiber Sound Systems**, the KK-60-UD is priced at \$17.95 per pair.

For More Details Circle (70) on Reply Card

Antenna Incorporated

U.S. MANUFACTURERS OF
**THE BEST IN
CITIZENS BAND
ANTENNAS**

PERSUADER
MODEL 17610
(STAINLESS STEEL WHIP)
\$25.95

PROTECTOR
MODEL 17620
(FIBERGLASS WHIP)
\$28.88

RUNK LIP MOUNT

Antenna, Incorporated
23850 Commerce Pk. Rd., Cleve., O. 44122
(216) 464-7075
In Canada: E. S. Gould Marketing Co., Ltd.

For More Details Circle (12) on Reply Card

**IT'S NO PUZZLE
TO ORDER**

OELRICH SERVICE FORMS

FOR TV-RADIO & 2 WAY RADIO SERVICE LEGAL FORMS FOR CALIF. FLA. UTAH NOW AT YOUR PARTS JOBBER OR WRITE FOR CATALOG B64
OELRICH PUBLICATIONS
4040 N. NASHVILLE AVE. CHICAGO, ILLINOIS 60634

For More Details Circle (13) on Reply Card

FREE CATALOG

HARD-TO-FIND PRECISION TOOLS

Lists more than 2500 items—pliers, tweezers, wire strippers, vacuum systems, relay tools, optical equipment, tool kits and cases. Also includes ten pages of useful "Tool Tips" to aid in tool selection.

JENSEN TOOLS
4117 N. 44th Street, Phoenix, Ariz. 85018

For More Details Circle (14) on Reply Card

endeco
soldering &
desoldering
equipment

SOLDERING IRONS

Pencil style. Safety light. Two heats — 20w and 40w. 6 tips. Unbreakable handle. 2 and 3 wire neoprene cords.

DESOLDERING IRONS

Pencil style. Safety light. Some operate at 40w, idle at 20w. 8 tip sizes. 2 and 3 wire neoprene cords.

SOLDERING & DESOLDERING KITS

Everything needed to solder or desolder or both. All in a handy lifetime metal box with hasp.

See your distributor or write...

Enterprise Development Corp.
5127 E. 65th St. • Indianapolis IN 46220
PHONE (317) 251-1231

For More Details Circle (18) on Reply Card

catalogs literature

Circle appropriate number on Reader Service Card.

100. Fordham Radio Supply Company—this discount mail-order catalog includes tools, service and repair kits, tubes, test equipment, phono cartridges and needles, speakers and microphones, antennas, components and many other servicing aids of major manufacturers. The catalog is illustrated and products are shown with discounted prices.

101. Mouser Electronics—manual #803 lists low-cost components, production aids, and test accessories complete with specifications, illustrations, and pricing information. The products listed include: Sanwa precision multimeters, tantalum capacitors, ultra-miniature toggle switches, 1/8-watt carbon-film resistors, batteries, knobs, semiconductors, wide-view panel meters, variable and isolation transformers, PC drafting aids, electronic chemicals, tools, and hardware.

102. Heath—the Heathkit catalog describes over 350 kits for nearly every do-it-yourself interest ranging from TV, radio, stereo and 4-channel hi-fi, to fishing, marine, R/C models, home appliances, electronic organs, automotive, test instruments, and others.

103. Klein—presents an 80-page catalog of specialized professional hand tools. Organized for easy reference and indexed both alphabetically and by product number, the catalog includes a selection of pliers, wrenches, screwdrivers, saws, hammers, levels, measuring tapes and rules, and many specialized electrical and electronic work tools, plus belts, tool pouches, and pockets. Tools and safety equipment are illustrated with large photographs and drawings.

104. Brookstone Company—makes available a 68-page catalog featuring hundreds of products sold rarely by industrial distributors or found in stores. The collection of products includes hard-to-find hand

tools and small power tools. A year's free subscription (six issues) is offered.

105. Precision Electric Company—offers a general catalog which describes their line of soldering equipment. Soldering irons, holders, tool and accessory kits, tips, aids, and pots are included. Size and heat specifications, and details of construction and materials are given.

106. Blonder-Tongue—makes available TV antenna-system layouts as a free design service to help improve dealer showroom systems. Information such as the number of channels in the area, number of TV sets on demonstration in the store, and diagram of the store layout indicating where the sets are located must be filled out on a TV-Showroom Layout-Request Form. When the form is returned, the B-T engineering department will custom-design an MATV system for the dealer showroom, and provide a price quote on what a new or upgraded system would cost.

107. International Rectifier—the Maintenance, Repair, and Operations catalog lists replacement components for industrial electronics equipment including germanium, silicon and selenium rectifiers, zener diodes, bridges, SCR's, protective devices and semiconductor fuses, switches and relays. Charts give complete specifications including voltage range, current rating, case style, and price information.

108. GC Electronics—has published a Service Technician and Industrial Catalog which contains descriptions and illustrations of nearly 2,000 items. The catalog, FR-75, covers the entire GC product line, including chemicals, alignment tools, printed circuit aids, technical aids, universal replacement parts and components, and electronic hardware. □

FREE ALARM CATALOG

Huge selection of burglar & fire systems, supplies. Motion detectors, infrared beams; controls, door switches, bells, sirens. 500 items, 99 pp. packed with technical details, notes.

(Outside U.S., send \$1.00.)
mountain west alarm
 4215 n. 16th st., phoenix, az. 85016



T & T VALUE SALE

RAYTHEON, I. C. C., RCA, SYLVANIA
 FAMOUS MAKE, NEW JOBBER BOXED TUBES
 NOW WITH NEW 5-YEAR GUARANTEE

- 80% OFF LIST
- | | | | |
|--------|--------------|---------|---------------|
| □ 1V2 | 5 for \$3.00 | □ 6HA5 | 5 for \$4.80 |
| □ 2AV2 | 5 for \$3.95 | □ 6HQ5 | 5 for \$6.35 |
| □ 3A3 | 5 for \$5.05 | □ 6HV5 | 5 for \$11.80 |
| □ 3AT2 | 5 for \$4.90 | □ 6JC6 | 5 for \$5.65 |
| □ 3GK5 | 5 for \$4.85 | □ 6JE6 | 5 for \$11.15 |
| □ 3HA5 | 5 for \$4.80 | □ 6JS6 | 5 for \$9.30 |
| □ 3HM5 | 5 for \$4.80 | □ 6JU8 | 5 for \$5.55 |
| □ 5GH8 | 5 for \$5.90 | □ 6KA8 | 5 for \$6.15 |
| □ 6AY3 | 5 for \$5.05 | □ 6KE8 | 5 for \$7.65 |
| □ 6BK4 | 5 for \$9.35 | □ 6KT8 | 5 for \$6.85 |
| □ 6CG3 | 5 for \$4.95 | □ 6KZ8 | 5 for \$5.15 |
| □ 6CG8 | 5 for \$5.40 | □ 6LB6 | 5 for \$10.75 |
| □ 6CJ3 | 5 for \$4.70 | □ 6LQ6 | 5 for \$11.15 |
| □ 6DW4 | 5 for \$4.70 | □ 8FQ7 | 5 for \$3.75 |
| □ 6EA8 | 5 for \$4.95 | □ 12B7 | 5 for \$4.50 |
| □ 6EH7 | 5 for \$4.80 | □ 12G7 | 5 for \$7.00 |
| □ 6EJ7 | 5 for \$4.50 | □ 17J28 | 5 for \$4.50 |
| □ 6F07 | 5 for \$3.75 | □ 23Z9 | 5 for \$6.00 |
| □ 6GF7 | 5 for \$6.65 | □ 33G7 | 5 for \$8.05 |
| □ 6GH8 | 5 for \$3.95 | □ 36MC6 | 5 for \$11.40 |
| □ 6GJ7 | 5 for \$3.40 | □ 38E7 | 5 for \$9.20 |
| □ 6GM6 | 5 for \$5.25 | □ 38H7 | 5 for \$9.00 |
| □ 6GU7 | 5 for \$5.25 | □ 42KN6 | 5 for \$9.15 |

What is not advertised—write in at 80% Off List
 One FREE 6GH8 for every 10 Tubes purchased from above.
 *A 6GH8 SPECIAL 100 for \$69.00

- SYLVANIA TUBES—NEW FACTORY BOXED
 70% & 10% OFF LIST ENTIRE LINE
- | | | | |
|--------|---------------|---------|---------------|
| □ 3A3 | 5 for \$6.82 | □ 6HA5 | 5 for \$6.48 |
| □ 6BK4 | 5 for \$12.62 | □ 6LB6 | 5 for \$14.51 |
| □ 6CJ3 | 5 for \$6.35 | □ 6LQ6 | 5 for \$15.05 |
| □ 6F07 | 5 for \$5.06 | □ 17J28 | 5 for \$6.08 |
| □ 6GH8 | 5 for \$5.33 | □ 23Z9 | 5 for \$8.10 |

- TRANSISTORS XACT. REPLACEMENT (BOXED)
 UP TO 85% OFF LIST
- | | | | |
|-------------|---------------|---------------|---------------|
| SK | ECG | SK | ECG |
| □ 3009-102A | 10 for \$5.85 | □ 3114-159 | 10 for \$3.60 |
| □ 3018-121 | 10 for \$3.38 | □ 3115-165 | 5 for \$12.40 |
| □ 3021-124 | 10 for \$4.73 | □ 3124-123A | 10 for \$3.15 |
| □ 3041-152 | 10 for \$6.30 | □ 3132 | 10 for \$3.90 |
| □ 3052-131 | 10 for \$5.85 | □ ECG 743 | 5 for \$14.75 |
| □ 3054-184 | 10 for \$6.75 | □ ECG 726 | 5 for \$10.00 |
| □ 3083-183 | 10 for \$6.30 | □ HEP 707 | 5 for \$12.50 |
| □ 3084-196 | 10 for \$7.20 | □ HEP 740 | 5 for \$12.50 |
| □ 3103-157 | 10 for \$4.50 | □ ZEN. 212-46 | 5 for \$10.00 |

- LARGE DISCOUNTS ON ALL TEST EQUIPMENT
 DIODES & RECTIFIERS
- | | | |
|---------------------------------------|--------------------|---------------|
| □ RCA Damper Diode Equiv. To: | □ RCA 135932 | \$2.95 |
| □ 6500 PIV Color Focus Rect. | 10 for \$5.00 | |
| □ 2.5 amp 1000 PIV IR-170 | 100 for \$8.95 | |
| □ DD04 | 10 for \$2.95 | |
| □ Zen. Voltage Tripler 212-136 Equiv. | 2 for \$8.00 | |
| □ Zen. Tripler Replacement 32-29778-3 | ea. \$9.95 | |
| □ 66 Meg. Res. | □ 53 Meg. Resistor | 20 for \$5.00 |

- YOKES-TUNERS-FLYS EQUIV.
- | | | | |
|-----------------------------|------------|-----------|-----------|
| □ Y94 | □ Y105 | □ Y107 | □ Y109 |
| □ Y119 | □ Y130 | □ DY107AC | □ 95-2779 |
| □ Syl. 51-29978E01 | ea. \$6.95 | | |
| □ Fly 277 H0601C | ea. \$7.95 | | |
| □ 4 Asst. Tuners, New | \$15.00 | | |
| □ 4 Asst. Combo Tuners, New | \$20.00 | | |

- AUDIO CARTRIDGES-SPEAKERS-NEEDLES REPL.
- | | | | | |
|-------------------------------------|----------------|--------|--------|--------------|
| □ 60 Min. Irish Cassette Tape | 12 for \$6.00 | | | |
| □ 90 Min. Cassette Norelco type box | 12 for \$10.00 | | | |
| □ 84 Min. Shamrock 8-Track Tape | 7 for \$6.00 | | | |
| □ 40 Min. Shamrock 8-Track Tape | 6 for \$4.00 | | | |
| □ Stereo Headphones | 4 for \$10.00 | | | |
| □ Stereo Headphone 25' Ext. Equip. | 10 for \$15.00 | | | |
| □ Picking V15 | ea. \$2.95 | | | |
| □ BSR Cart. | □ SX5M | □ SX1M | □ SC5M | 4 for \$6.00 |
| □ 12 Asst. Needles incl. Diamond | \$4.95 | | | |
| □ BSR Adaptors (45) | 6 for \$2.00 | | | |
| □ Pillow Speakers | 10 for \$6.95 | | | |
| □ Universal AC Adaptor, 5v, 75v, 9v | ea. \$3.95 | | | |

- ANTENNAS
- | | |
|--|-----------------|
| □ 72 ohm to 300 ohm Matching Transformer | 10 for \$7.50 |
| □ 59U "F" Connectors | 100 for \$10.00 |
| □ 8 Antenna Clothespins | \$1.19 |

- GENERAL
- | | |
|--|---------------|
| □ 19 & 25", 21" Color Boosters | 3 for \$11.95 |
| □ Bellfuses 2250-1 | 25 for \$2.50 |
| □ HV 30KV Anode Leads | 6 for \$1.29 |
| □ SHUNT Reg. HOODS (6BK4) | 3 for \$1.29 |
| □ Color CRT Harness | 8 for \$1.29 |
| □ Panasonic Focus Resistors Pt. #ERRIOF JK167P | ea. \$3.50 |
| □ Panasonic TSA 965-5 Antenna | ea. \$2.25 |

FREE MERCHANDISE WITH ANY ORDER
 □ 100 Asst. Carbon Resistors □ 5 Asst. Filter Cans □ 10 Asst. Condensers
 □ 50 Asst. Controls □ 10 Asst. slide switches □ Philco Color Fly H0652C
 LETTERS OF CREDIT AND ALL CHECKS
 PLACED ON DEPOSIT WITH
 MANUFACTURERS HANOVER TRUST BANK N. Y. C.
 Minimum Orders \$50—F. O. B. Brooklyn, N. Y.
 Catalogs \$1—Refundable upon your order
 C. O. D.'s 50% Deposit—CASH ONLY

T & T SALES CO.

4802 AVENUE K
 BROOKLYN, N. Y. 11234
 Phone: (212) 241-5940

The MARKETPLACE

This classified section is available to electronic technicians and owners or managers of service shops who have for sale surplus supplies and equipment or who are seeking employment or recruiting employees.

Advertising Rates
in the Classified
Section are:

- 25 cents per word
(minimum \$3.00)
- "Blind" ads \$2.00
additional
- All letters capitalized
35 cents per word

Each ad insertion must be accompanied by a check for the full cost of the ad.

Deadline for acceptance is 30 days prior to the date of the issue in which the ad is to be published.

This classified section is not open to the regular paid product advertising of manufacturers.

FOR SALE

UNUSUAL SURPLUS AND PARTS Catalog. \$1. ETCO Electronics Dept. E.S., Box 741, Montreal "A" H3C 2V2. 12-74-12t

DON'T JUNK THAT T.V.—We have the most complete stock of T.V. picture tubes in U.S. B & W and color, old or new, over 1700 types at the lowest prices. ALLIED SALES, Pimento, Indiana 47866, 812-495-5555. 8-75-3t

SENCORE EQUIPMENT—(PS 163) Duel Channel Scope - \$500.00. SM-152 Sweeper - \$315.00. FE-23 Little Henry Multimeter - \$50.00. Big Mack (CR 168) Crt Tester - \$175.00. CG-169 Color Bar Generator - \$150.00. BE-156 Bias Supply - \$20.00. HEATH VECTORSCOPE & color bar generator - Model 10-101 - \$110.00. B & K model 970 Transistor Equipment Analyst - \$175.00. B & K model 960 Transistor Radio Analyst - \$75.00. Richard Sanderford, 6400 Andy Drive, Raleigh, N.C. 27610, (919) 834-3504. 10-75-1t

ANTIQUE RADIO DIAGRAMS—244-page large manual, covering 1926-1938. Only \$7. Lawrence Beitman, 409-E Chalmers, Champaign, Illinois 61820. 10-75-1t

TEKTRONIX SCOPES, HP generators, other test and electronic equipment. ELECTRONIC SPECIALTIES, 1659 Wetmore, Tucson, Arizona 85705. 10-75-1t

CRT Rebuilding Equipment accessories included. Complete outfit. \$5,000. worth now only \$3500.00. Used about 8 months. Lakeside Brand. 904-377-4569. Gainesville, Fla. 32601. 10-75-1t

SAMS PHOTOFACETS 1 thru 1493 complete and excellent. \$1600. C.W. Riley, 715 Angela Dr., Normal, Ill. 61761, 309-452-4593. 10-75-1t

SAMS PHOTOFACETS like new condition #500 Sept. 1960 through #1500, July 1975, in four 4-drawer metal cabinets \$1600.00 FOB Naples, or deliver Free anywhere in South Florida. Frank Tenney, P.O. Box 1216, Naples, Fla. 33940. Phone 813-261-1383. 10-75-1t

FOR SALE (CONT.)

HI-FI SPEAKER System Bargains - HARTLEY Concertmaster Mark VI \$547.00 each. HARTLEY Zodiac II, teak or rosewood \$59.00 each. All are prime demo units with warrantee card. Paul Tarallo, 1 Beaumont Circle, Yonkers, New York 10710. 10-75-1t

CONVERT any transistorized T.V. tuner to a tuner substituter. Plans \$2.00. New accelerated Radio & T.V. course. RADIO TELEVISION TRAINING, Box 279, ES-105, Syracuse, N.Y. 13206. 8-75-tf

NEW Canadian Magazine "Electronics Workshop". \$5.00 yearly. Sample \$1.00. Ethko, Box 741, Montreal "A" Canada. 10-75-12t

EDUCATION-INSTRUCTION

TV PROBLEMS?? Send symptoms with a copy of schematic and self-addressed stamped envelope and \$1.00 to Troubleshooter, Box 4553, Downey, Ca. 90241. Results Guaranteed. 9-75-1f

REPAIR TV TUNERS—High Earnings; Complete Course Details, 12 Repair Tricks, Many Plans, Two Lessons, all for \$2. Refundable. Frank Bocek, Box 3236 Enterprise, Redding, Calif. 96001. 10-75-6t

WANTED

WANTED: Used picture tube rebuilding equipment. Robert Nelson, 3602 Mt. Aclare, San Diego, Calif. 92111. 10-75-1t

BUSINESS OPPORTUNITY

BUSINESS OPPORTUNITY: Social Security will not let me retire with a business. Sacrifice Radio & TV Sales & Service, truck, inventory, business all for \$20,000.00. Same Location over 26 years. Last year gross over \$147,000.00. Call after 6 o'clock 713-823-7317 or write 713 S. Main Bryan, Texas 77801. 10-75-1t

ESTABLISHED TV Repair & Picture Tube Rebuilding Shop Located in Beautiful San Diego, Calif. Sickness Forces Sale. Business, Equipment & Stock For Only \$18,000. Call 714-298-5501 or 714-263-1538. For More Information. 10-75-1t

WELL ESTABLISHED thriving television sales and service shop - Fully equipped - For Van - Located in progressive university town - near St. Louis, Mo. - Choice location - carpeted showroom. Write: Dept. 507, Electronic Servicing, 1014 Wyandotte St., Kansas City, Mo. 64105. 10-75-1t

advertisers' index

American Technology Corp.	9
The Antenna Company, Inc.	52
Bussmann Mfg. Div., McGraw-Edison	1
Castle TV Tuner Service, Inc. Cover	4
Enterprise Development Corp.	52
General Electric Company	13
Heath Company	45
Jensen Tools and Alloys	52
Mountain West Alarm Supply Co. . .	53
Nikoltronic	35
Oelrich Publications	52
Perma-Power Company	47
Precision Tuner Service	Cover 2
RCA Distributor and Special Products . . .	9, 14, 15, Cover 3
Sperry Tech, Inc.	12

GTE Sylvania- Consumer Renewal	28-29
T&T Sales Company	53
Tab Books	48
Tuner Service Corporation	7
Weller-Xcelite, Inc.	51
Winegard Company	10-11



"I'VE DECIDED TO ACCEPT YOUR ROOF-TOP ANTENNA INSTALLATION OFFER."

(Continued from page 16)

Solution to: TIME TO GO OHM

- | | |
|----------------|----------------|
| 1. troposphere | 13. transform |
| 2. bolometer | 14. constants |
| 3. clockwise | 15. impedance |
| 4. decrement | 16. clearance |
| 5. scrambler | 17. barretter |
| 6. striation | 18. inductance |
| 7. ferristor | 19. shielding |
| 8. aperiodic | 20. parabolic |
| 9. amplitude | 21. transpose |
| 10. luminance | 22. bedspring |
| 11. deuterium | 23. oxidation |
| 12. afterglow | 24. limiter |
| | 25. moire |

**Start with 100 points
and deduct 4 points for
any part you may not
have answered correctly.**

Your rating:

- Less than 60—Shhhhhhhhhhh!
60 - 64 Fair.
68 - 72 Good.
76 - 84 Very good.
88 - 96 Excellent.
100 PERFECT!
You win our imaginary trophy!

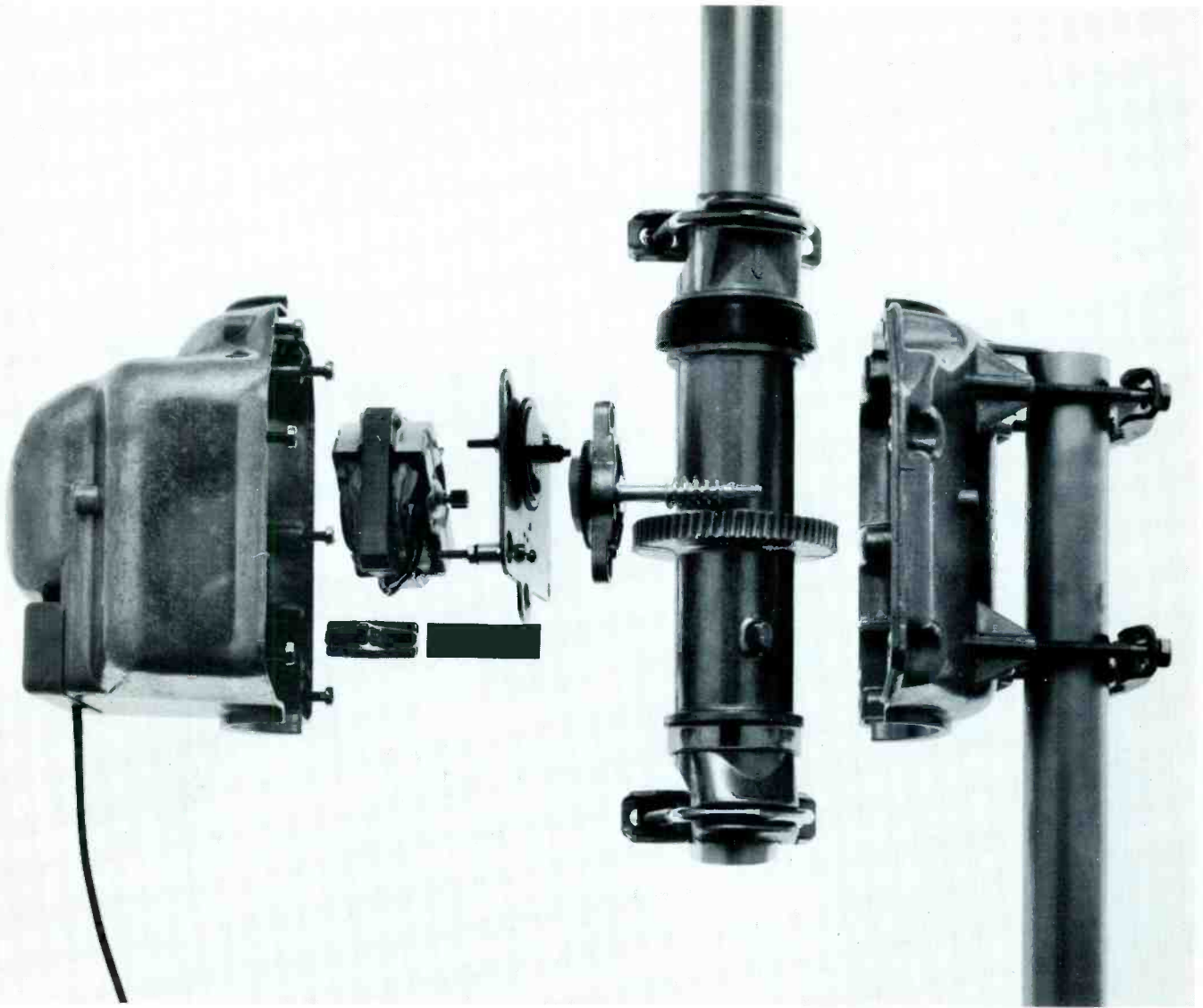

“RCA warrants this product against defects in materials and workmanship for a period of two years from date of purchase...”

RCA's Selecta-Channel Automatic Rotator carries the only 2-year warranty from a major company.

The Drive Unit for model 10W606 (shown above) features an easily removable high-tensile aluminum alloy housing. Inside, a powerful high efficiency motor. Permanently lubricated oversize stainless steel bearings — no external thrust bearings are required. Quick-connect pressure terminals. A new mast mounting that won't snag lead-in wires. Premounted hardware, and a reinforced shaft.



The Control Unit is an attractive chrome-trimmed beige, with cushioned base. The transparent "direct select" control knob has a moving direction indicator light showing the antenna's exact position. And, it's quiet: no click-clack sound.

For more information on the 10W606 or the deluxe Automatic Rotator 10W707, call your RCA Distributor. Or contact RCA Distributor and Special Products Division, Building 206-2, Cherry Hill Offices, Camden, New Jersey 08101.

**RCA
Rotators**



CASTLE Timesavers ... for the Professional

SUBBER® TV signal circuit analysts

Analyze the ENTIRE signal circuit system of any Color or Black & White Television receiver . . . by signal substitution.

Outputs at video i.f., sound i.f., video and audio.

- Inbuilt monopole antenna • Inbuilt loudspeaker • Video carrier level meter • Battery indicator meter

Use on the bench or in the home . . . anywhere.

Complete with 120vac wall plug-in transformer and matched test cables.



MASTER SUBBER® Analyst Mk V net \$169.95

*UHF-VHF
TV tuner and i-f
signal analyst
120 VAC + Battery*



**Mark IV-CUV
net \$64.95**

*TV tuner and i-f
signal analyst
120 VAC + Battery*



**Mark IV-C
net \$54.95**

MEZZER™ TV Field Strength Meters

Use for measurements of TV signals in:—

- Antenna installation • Antenna evaluation • CATV
- MATV • Output calibration of TV signal generators.

TV Service VHF Field Strength Meter

- Simple to operate
- Measures 300 μ V to 30,000 μ V.
- Uses ordinary 9v transistor batteries

**Model TVS
net \$69.95**



VHF Field Strength Meter

Range: 20 microvolts to 100 millivolts.
Attenuator: x 1, x 10, x 100.
Inputs: 75 & 300 ohms.
120vac & batteries

**Model FSM-V
net \$119.95**



UHF Field Strength Meter

Range: 20 microvolts to 10 millivolts.
Attenuator: x 1 and x 10.
Inputs: 75 & 300 ohms.
120vac & batteries

**Model FSM-U
net \$99.95**



Castle products — advanced technology — modern styling — and they work!

Ask your electronic distributor for them . . . or write for more details.

CASTLE ELECTRONICS, INC. 5701 N. Western Ave., Chicago, Ill. 60645 • Ph. (312) 728-1800

For More Details Circle (2) on Reply Card